

Schnitt A - A M 1 : 20

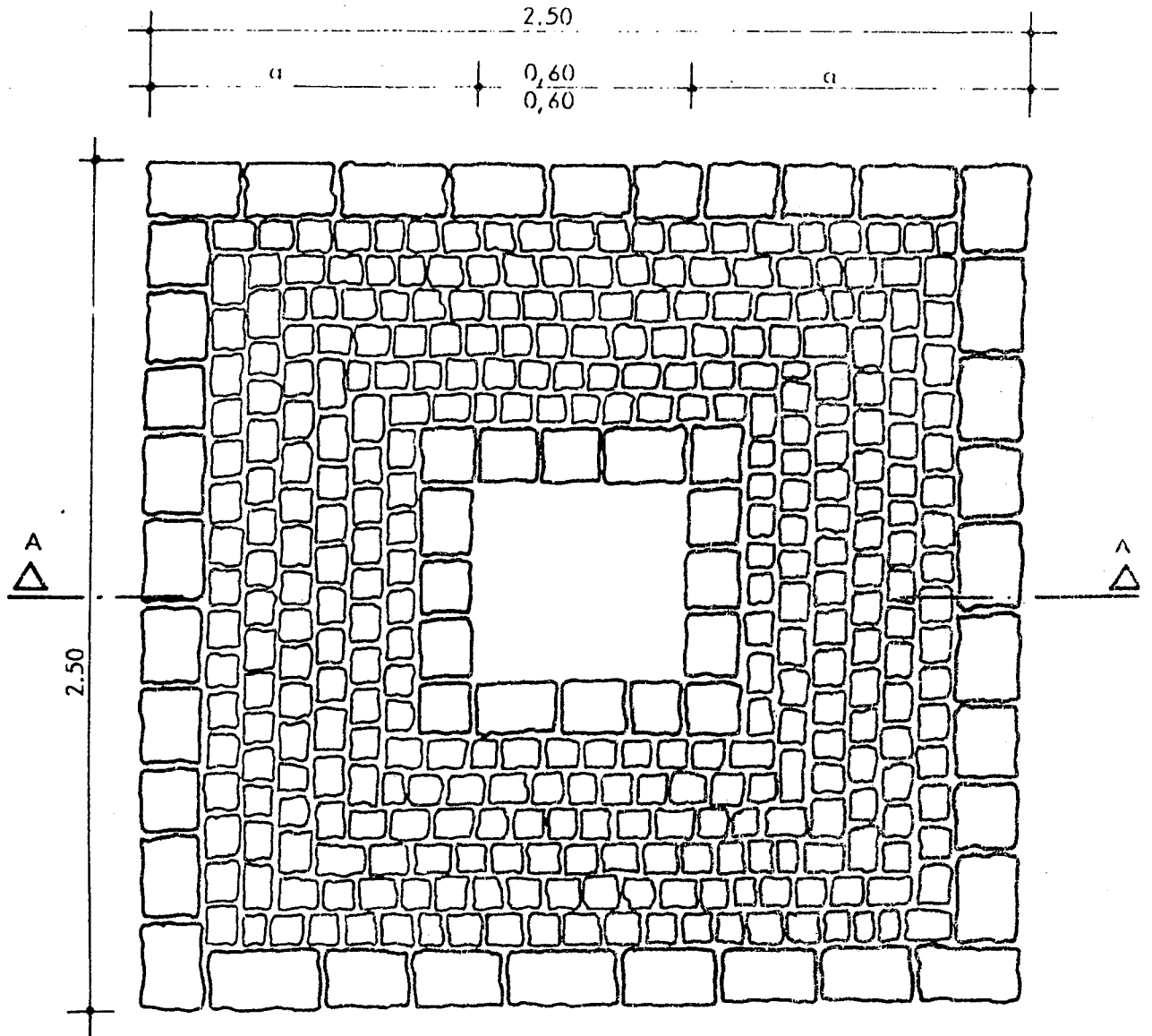

Grundriss M 1 : 20

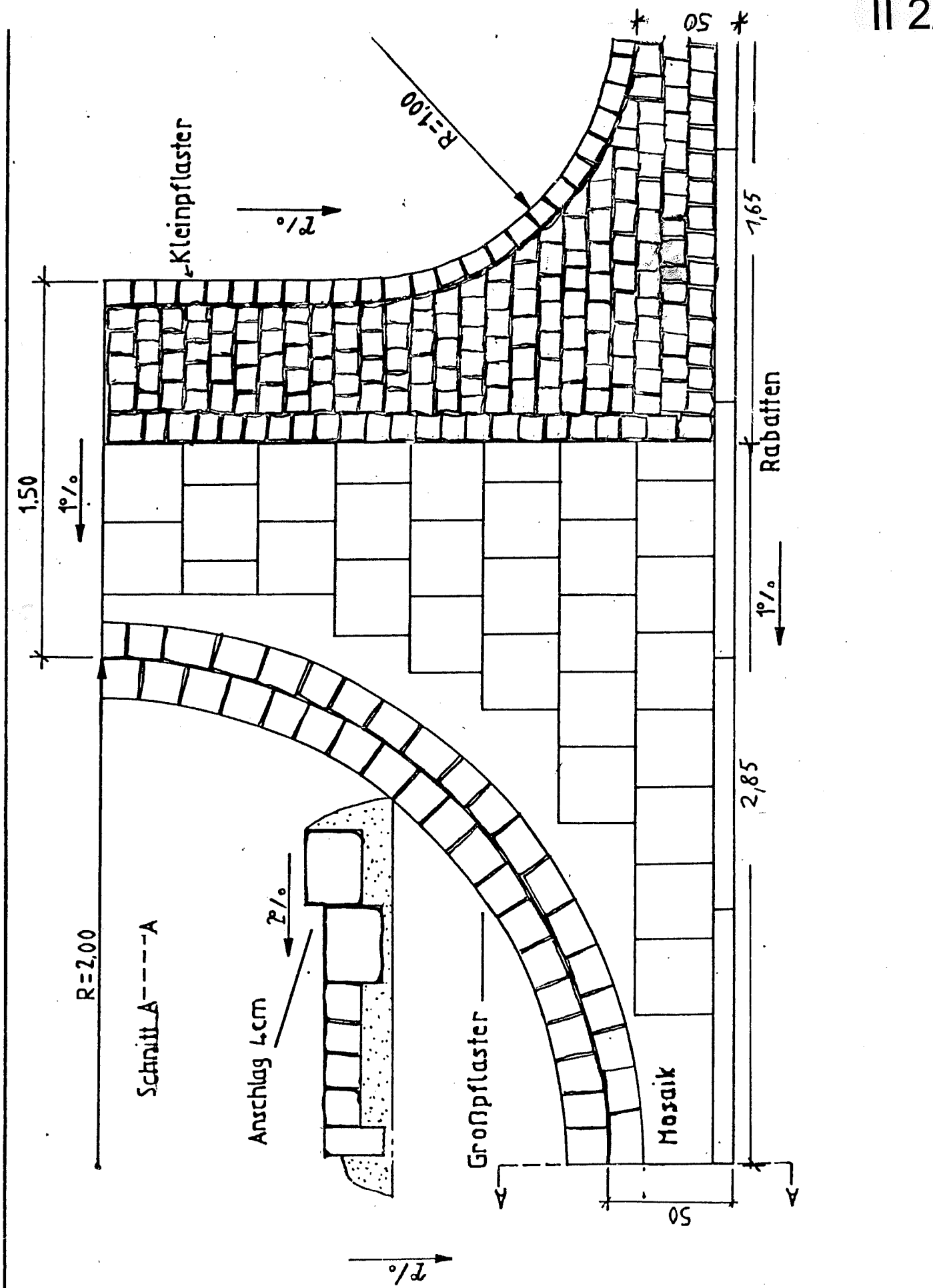

AZ BAU
GERADSTETTEN

EINMÜNDUNG R=2 / R=1

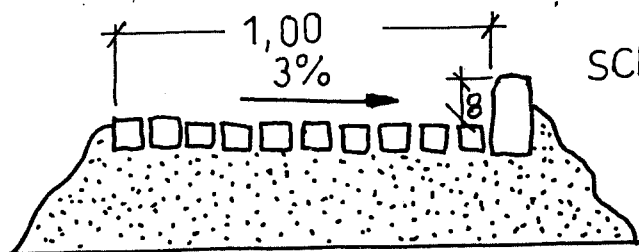

SCHNITT B - B

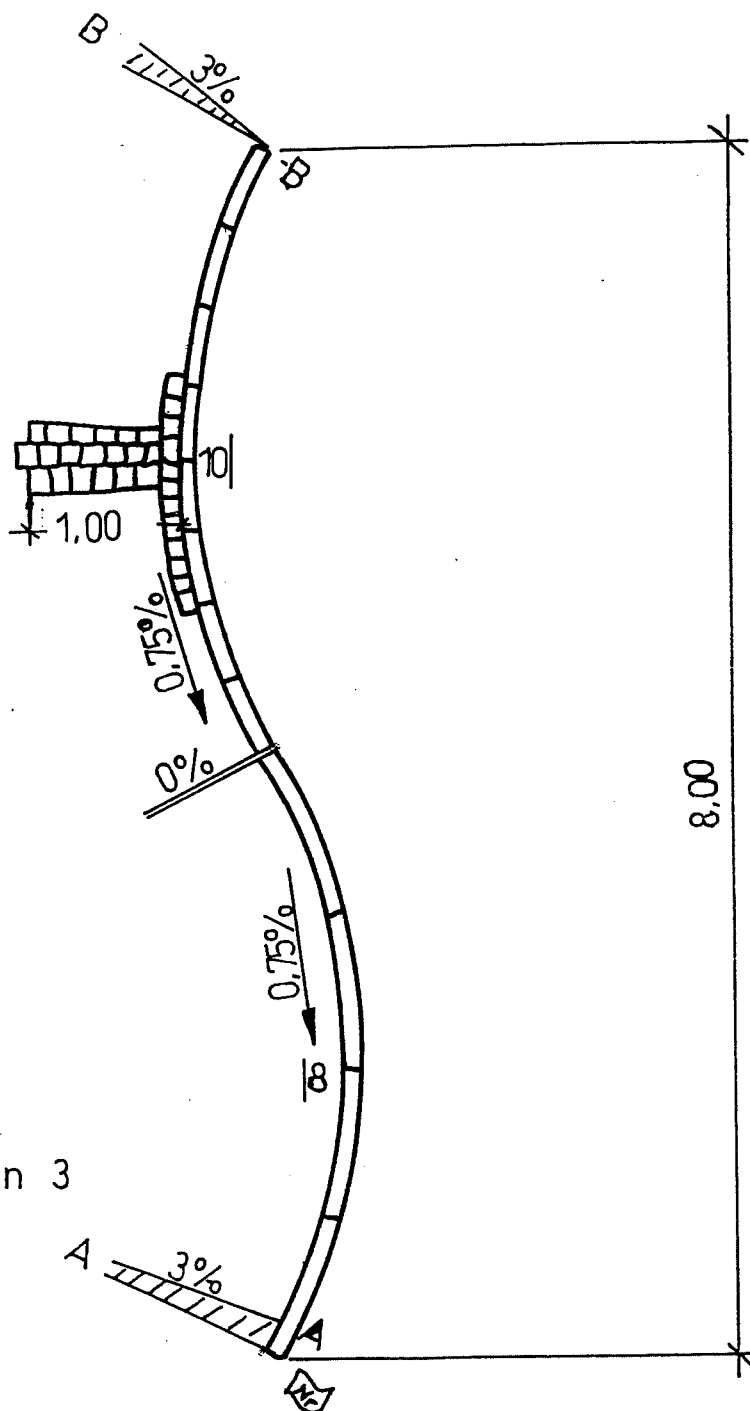

Gehwegplatten in 3

Längsreihen

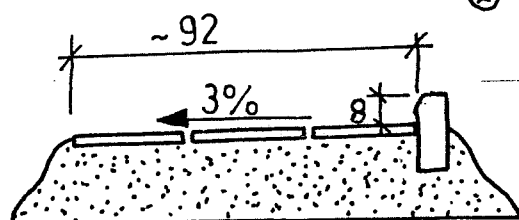

Schnitt A - A

AZ Bau	WENDELINIE 8,00			
Geradstetten				

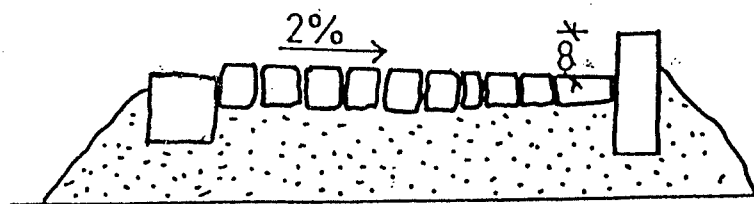
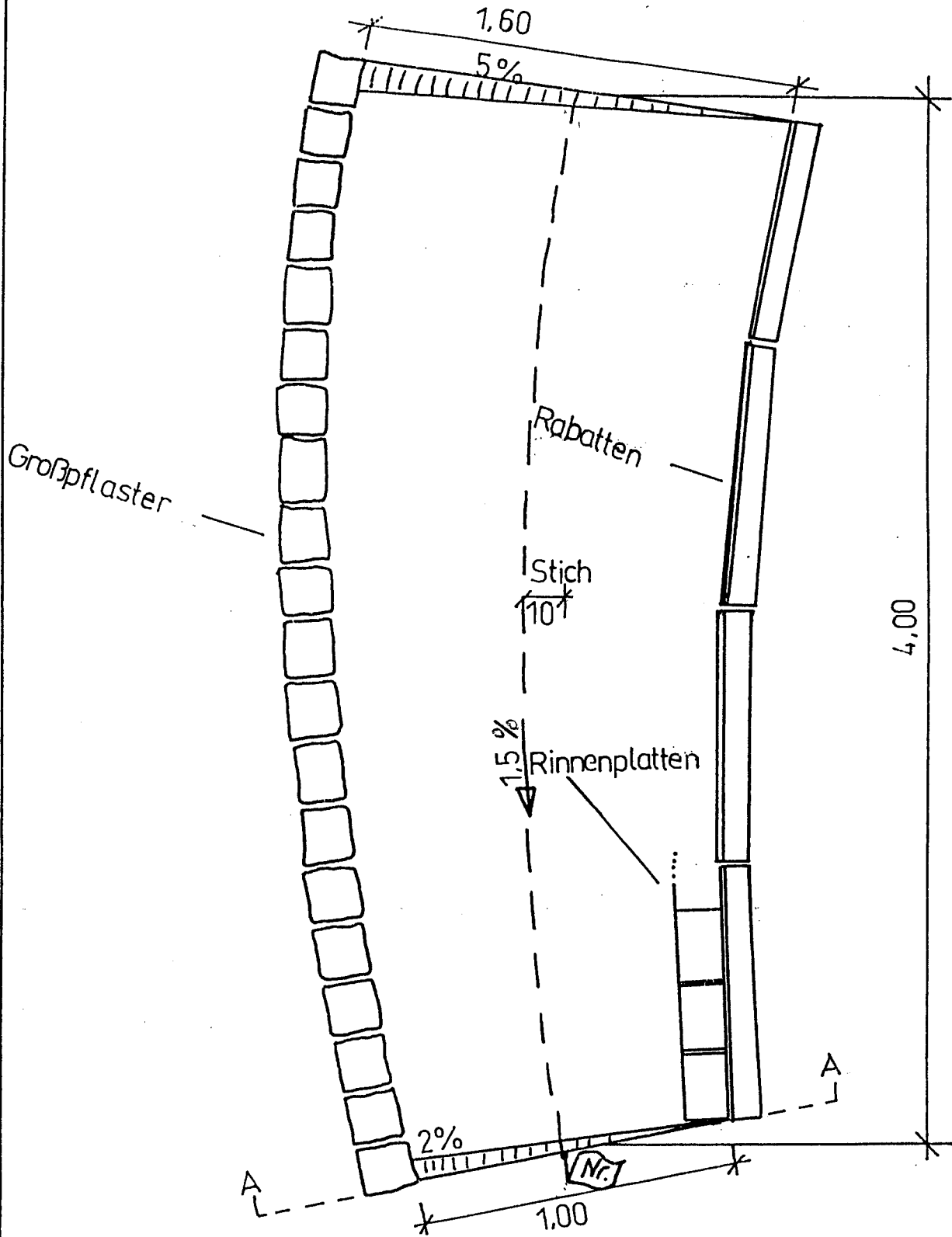

Schnitt A-A

AZ Bau
Geradstetten

GEHWEGAUFWEITUNG

OHNE M:

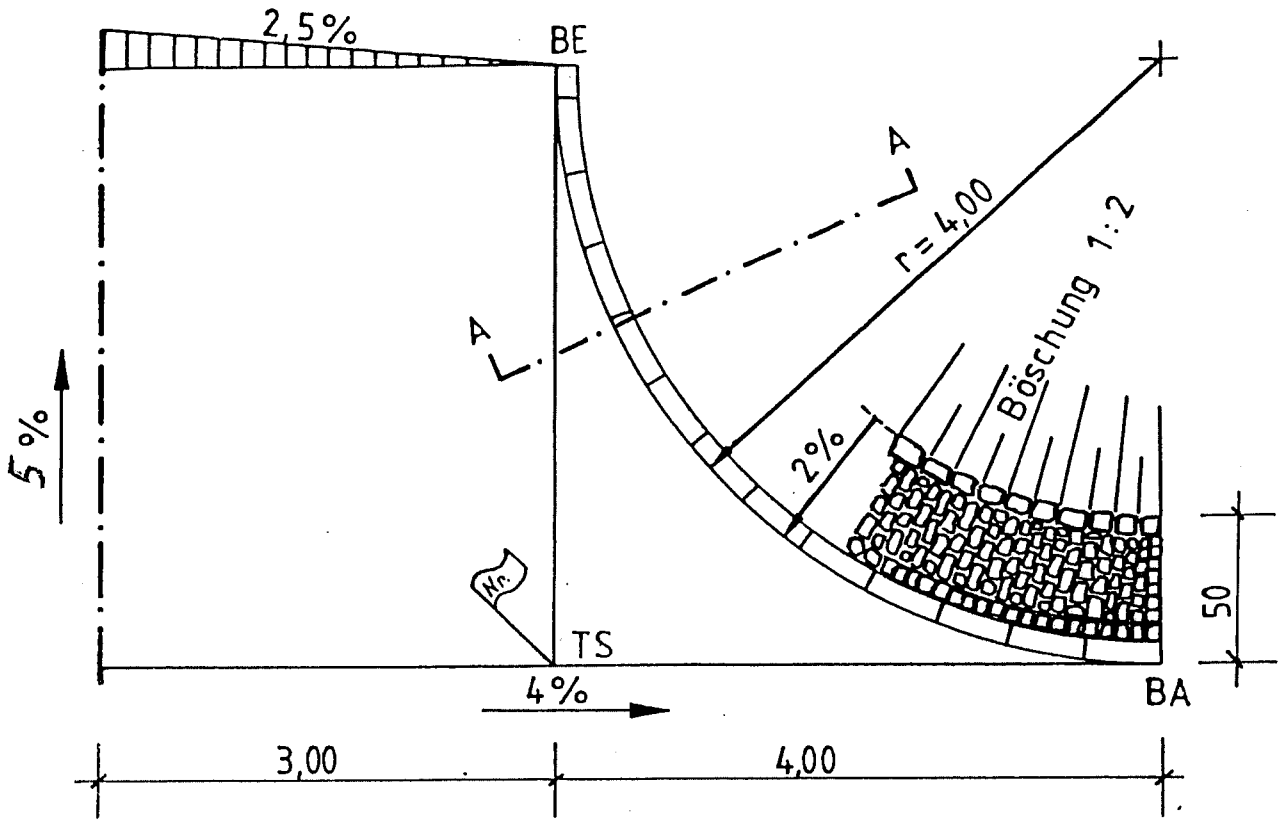

Schnitt A - A

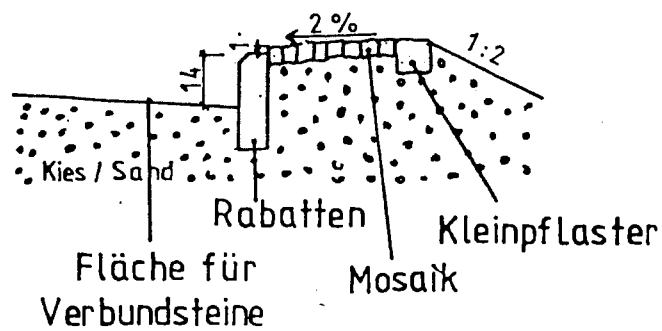

Eckausrundung $r = 4,00\text{m}$
mit Sicherheitsstreifen

A-A

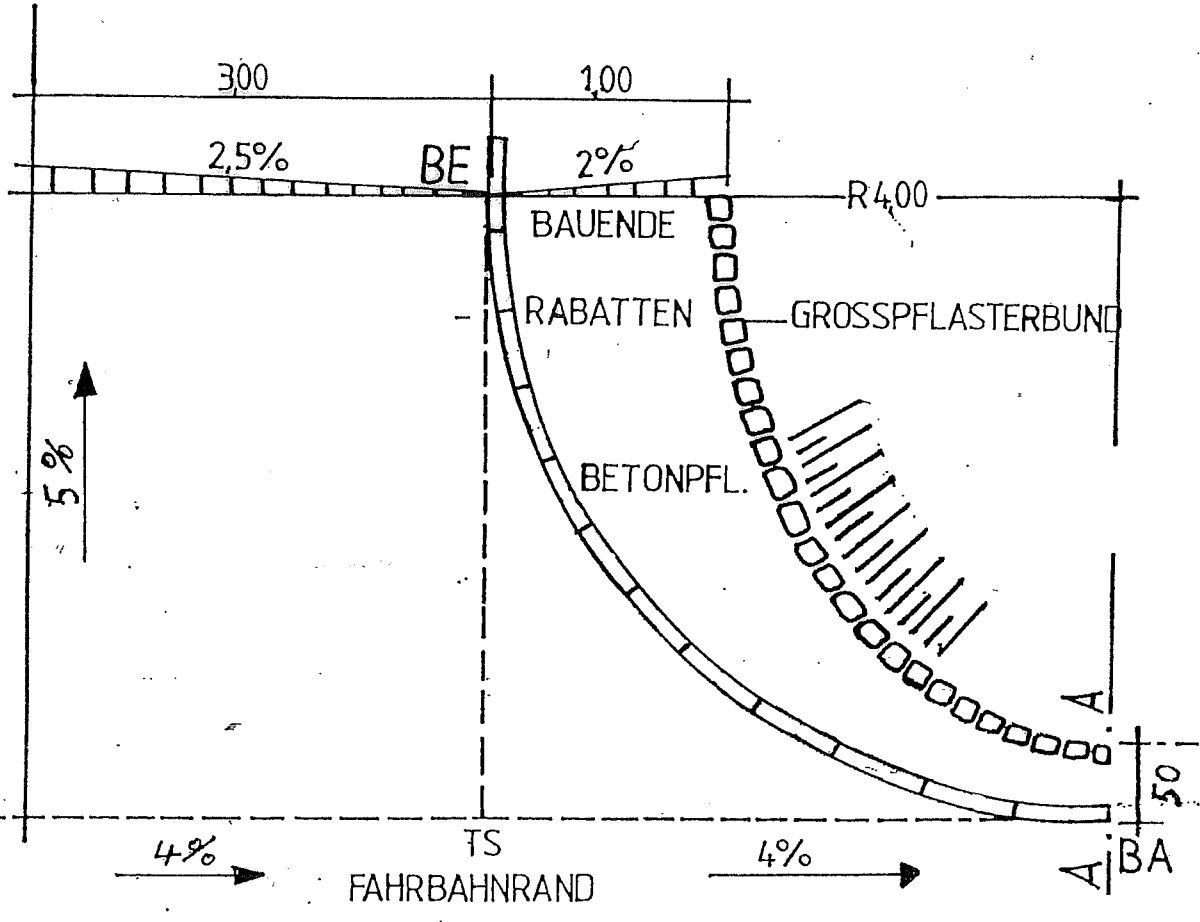
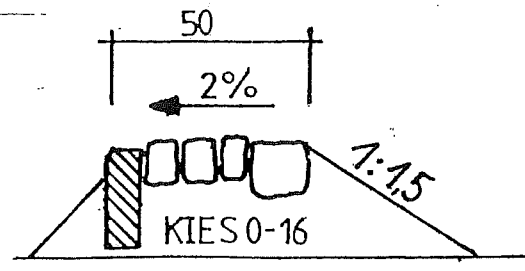

R=4 mit auslaufendem Gehweg

A-A

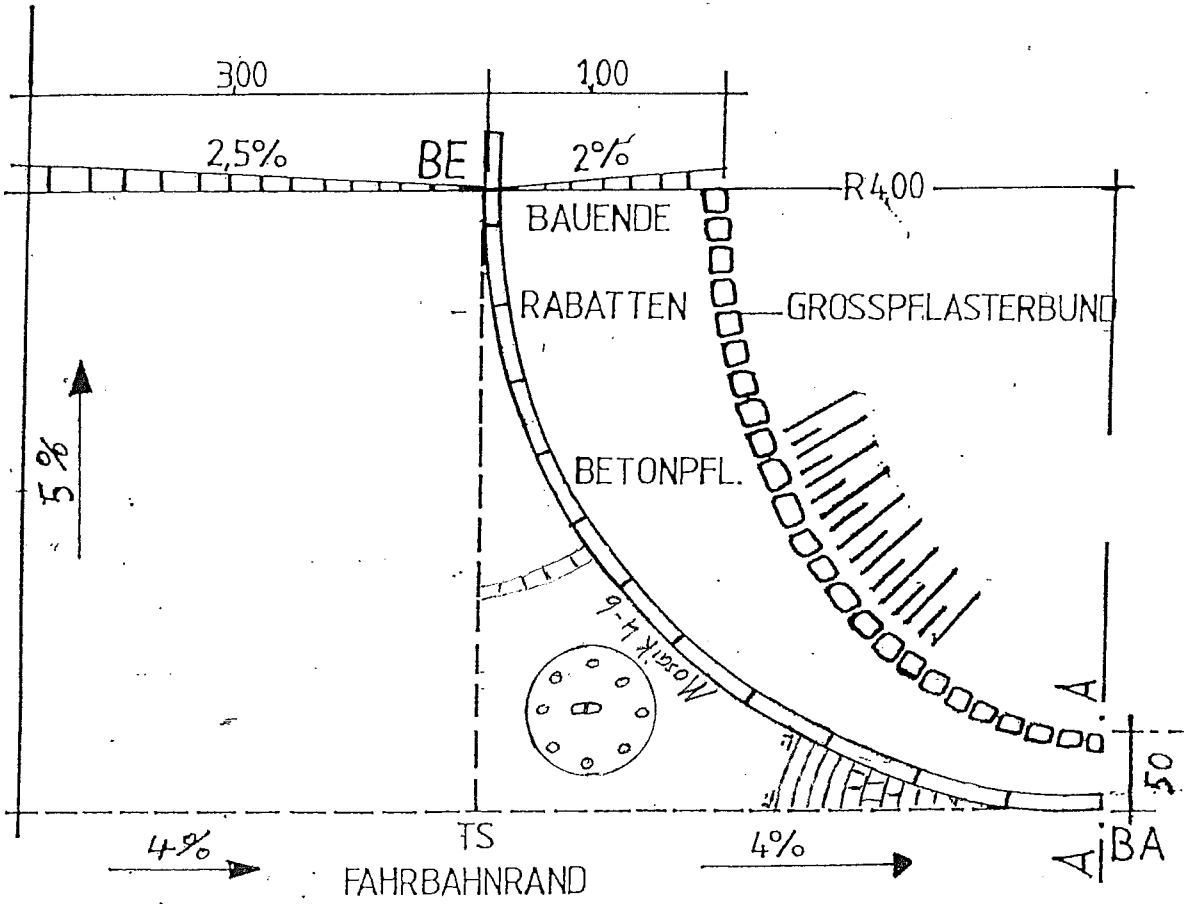
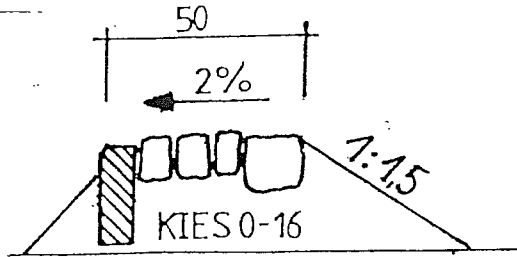

R=4 mit auslaufendem Gehweg

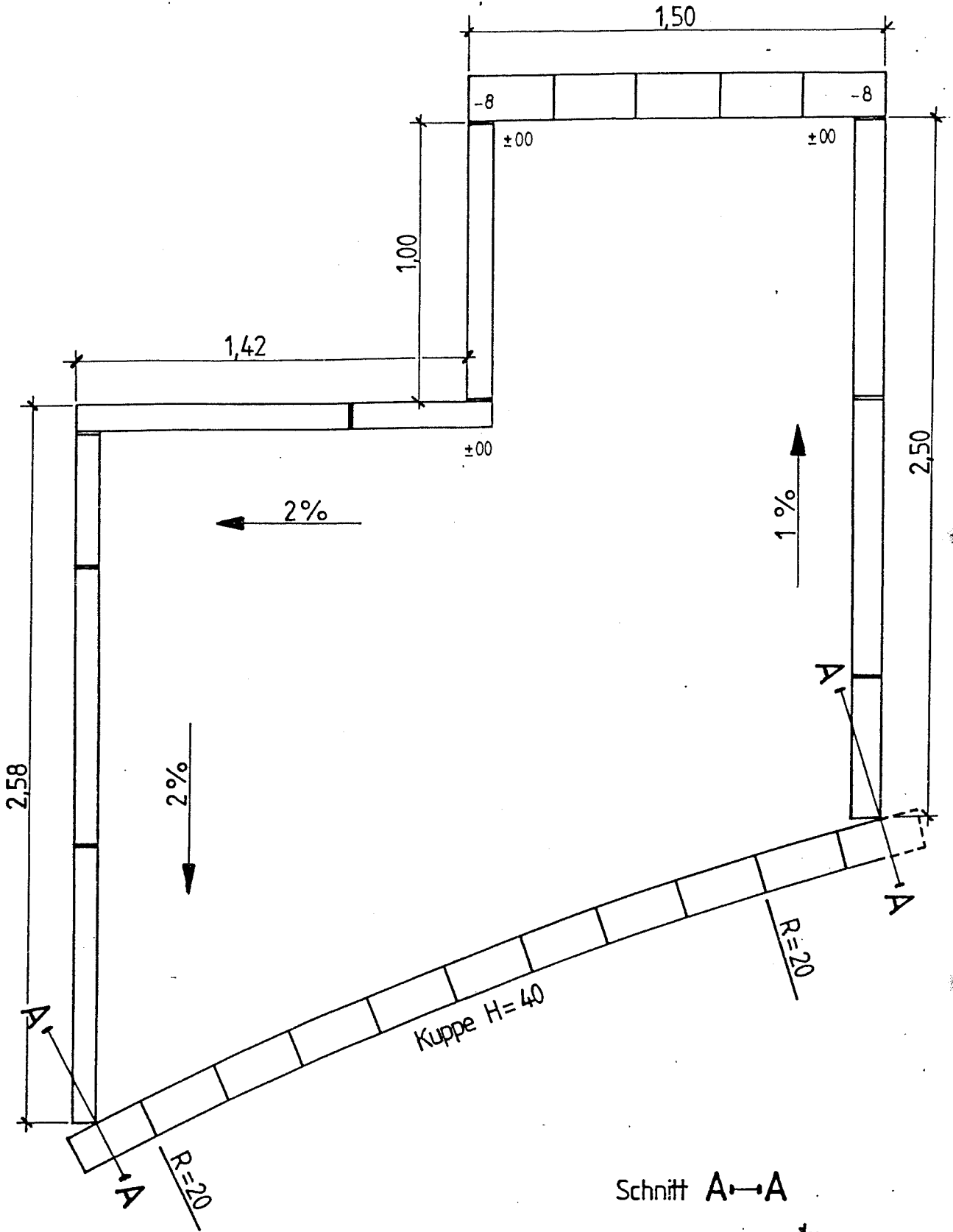

Schnitt A-A

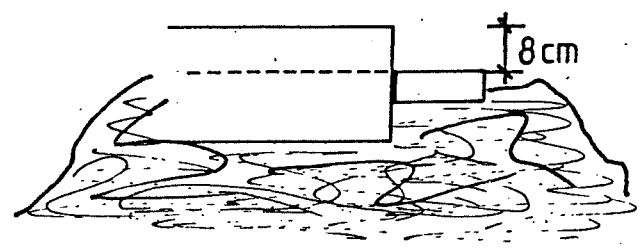

Einstellfläche /
Garageneinfahrt

M= 1:20

LAGEPLAN

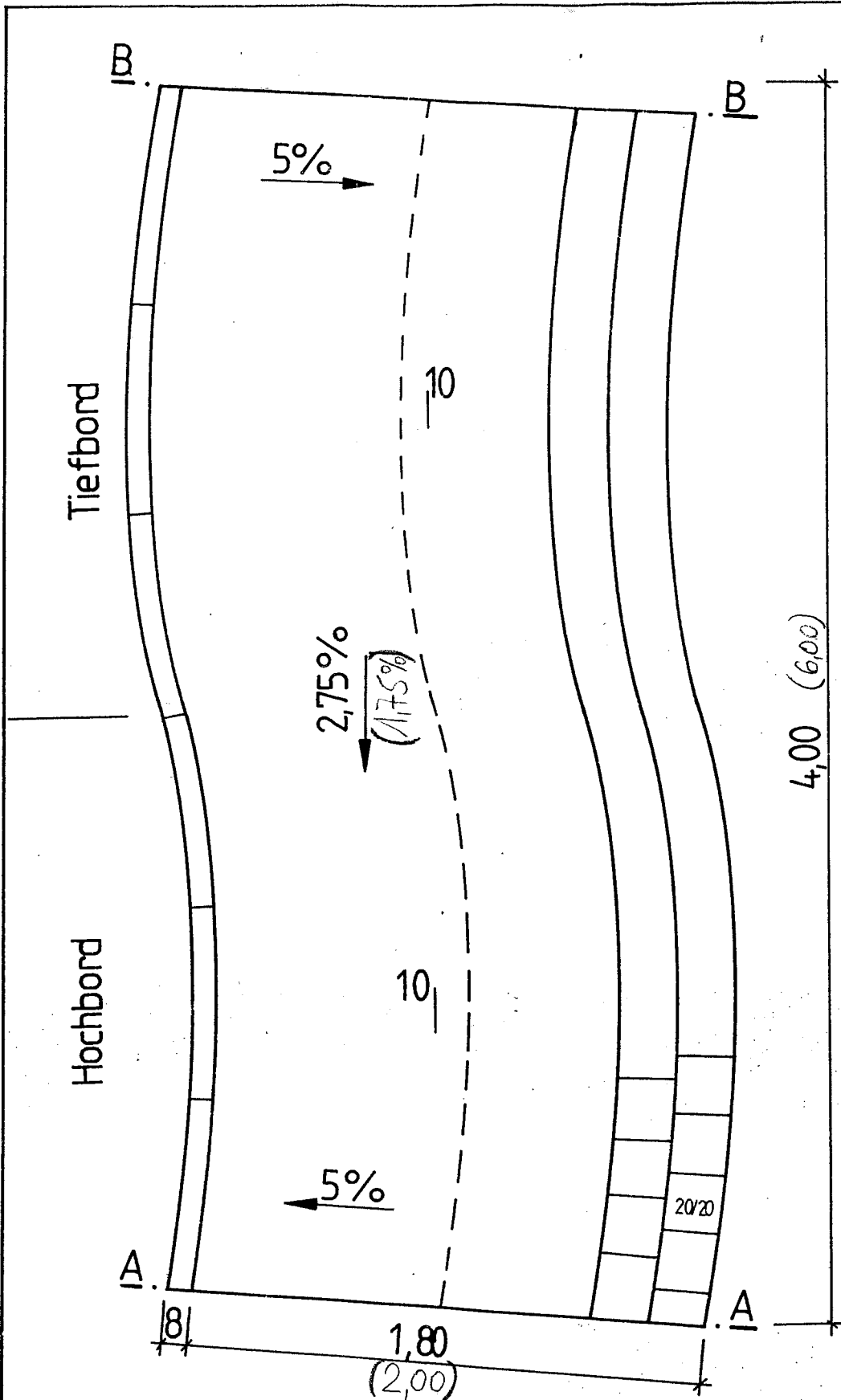

4,00 (6,00)

SCHNITTE



AZ Bau	WENDELINIE		
Geradstetten			

SCHNITT A - A

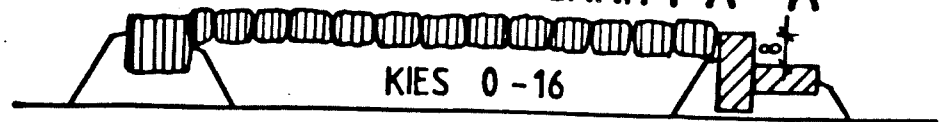

2%

MULDENAUSRUNDUNG / H=50

GROSSPLASTER in einer Visur

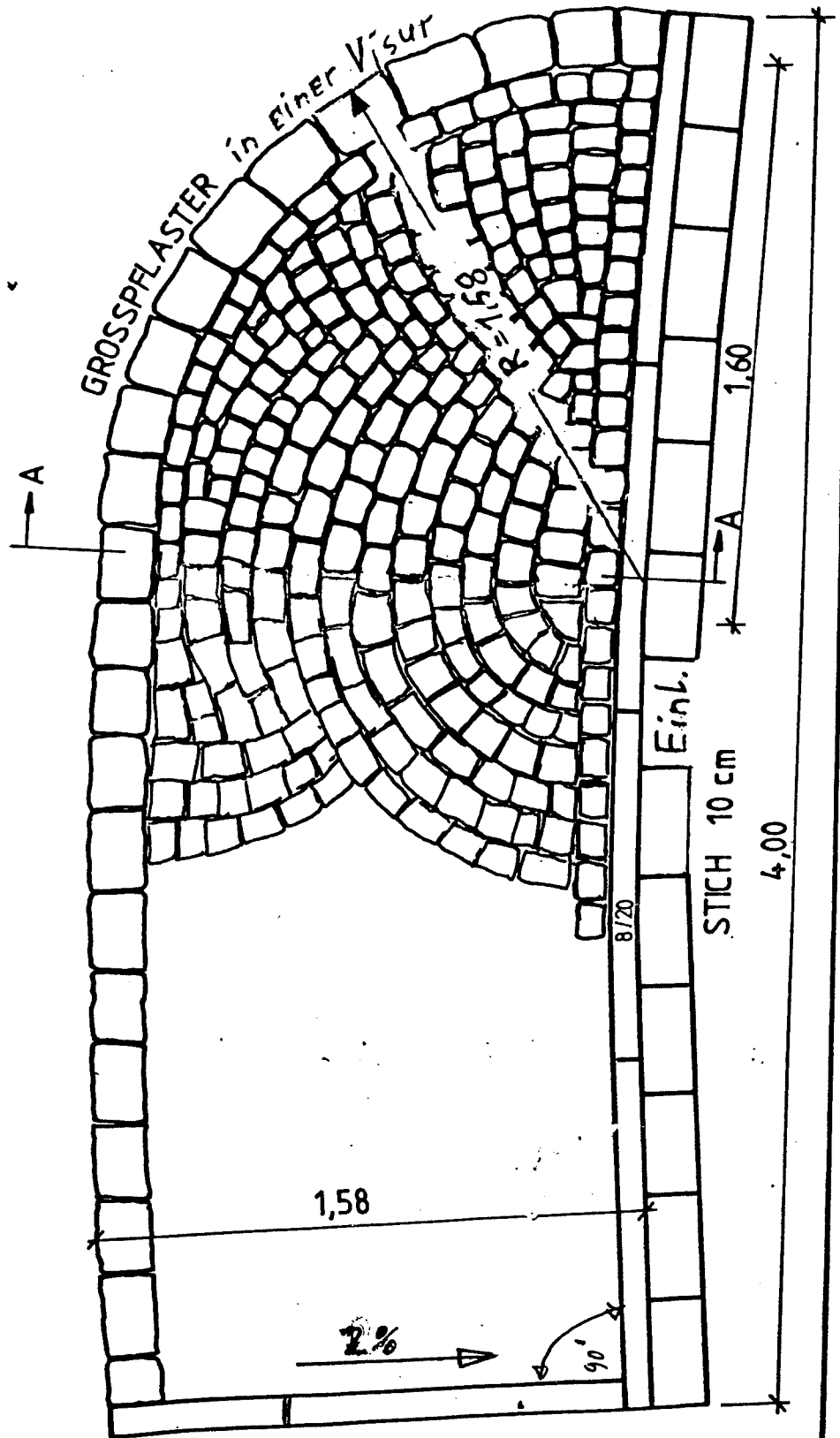

DRAUFSICHT

AZ - Bau

STRASSENBAU

M=

Gieradstatten

Verkehrinsel

1:20

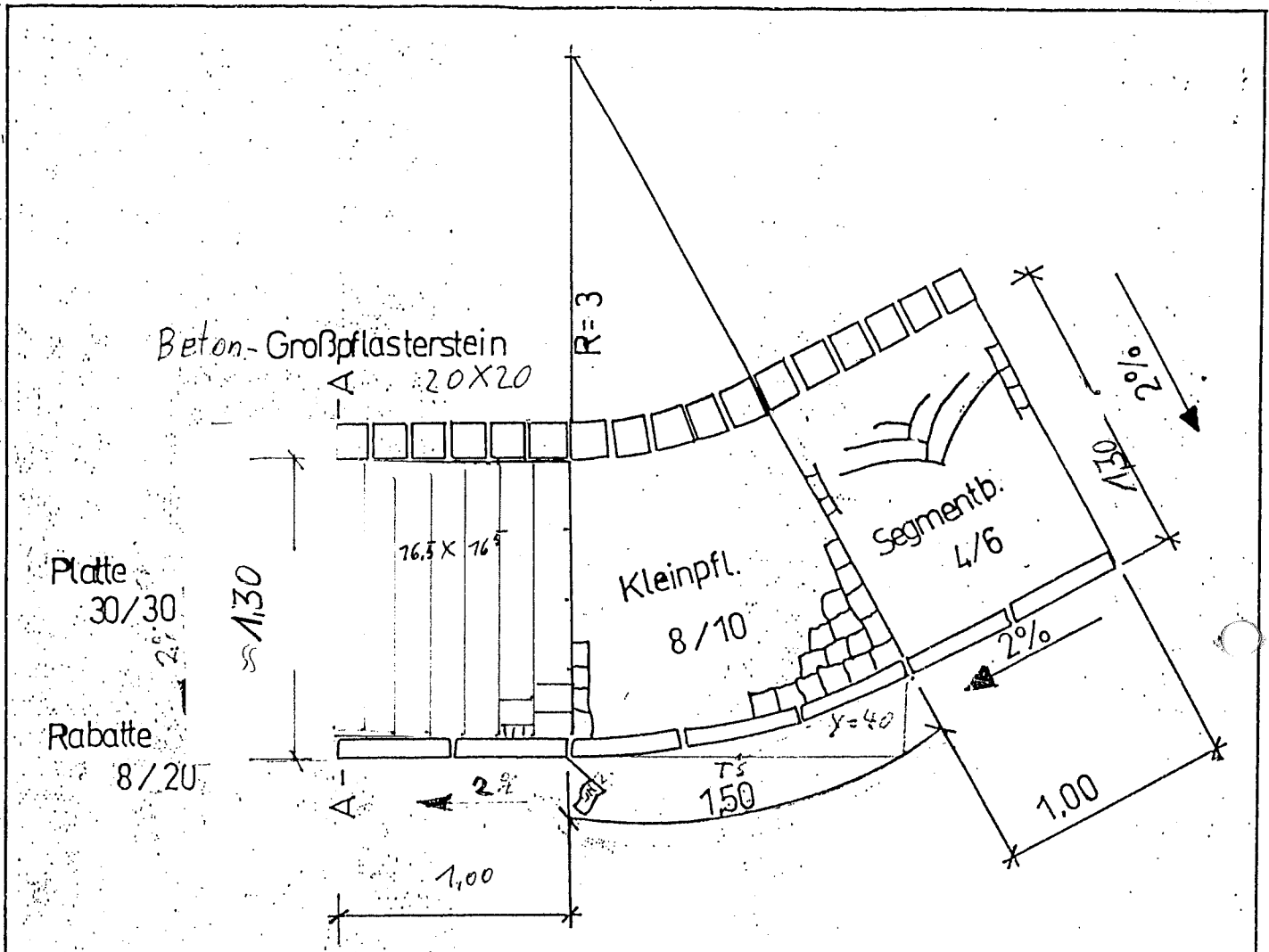

Schnitt A-A

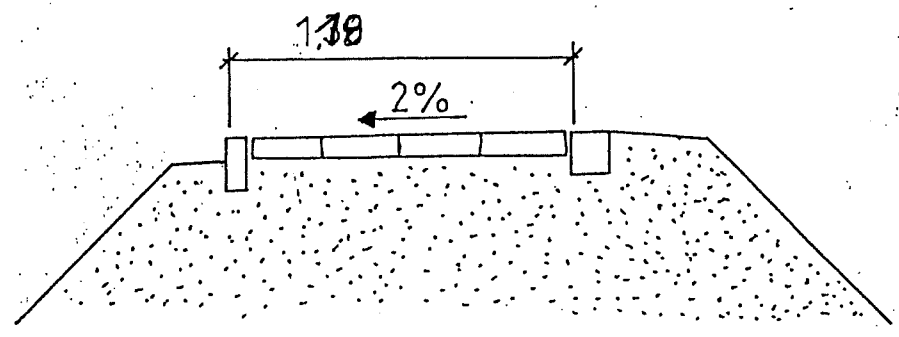

AZ Bau	GEHWEG R=3		
--------	------------	--	--

Draufsicht

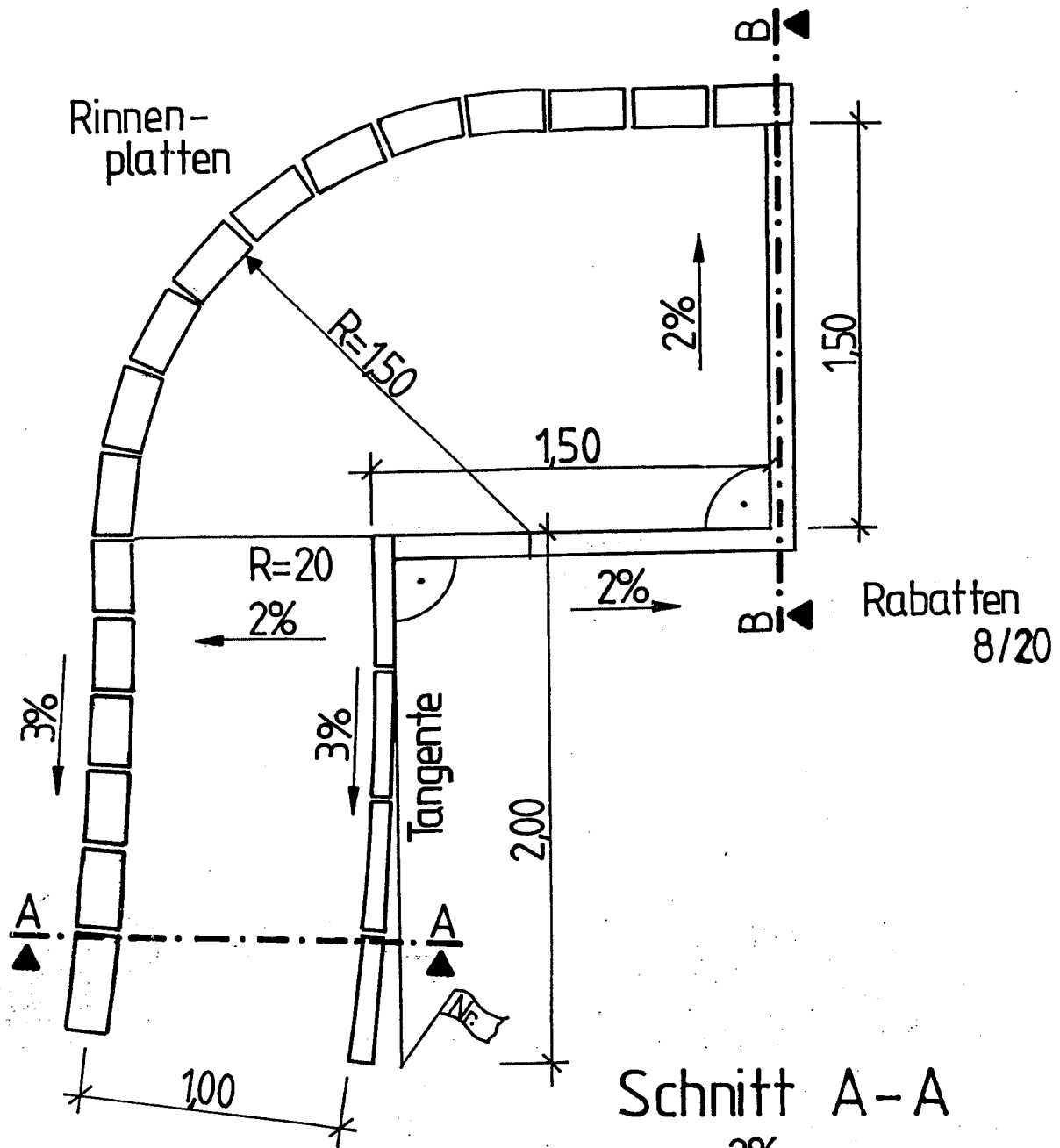

Schnitt A-A

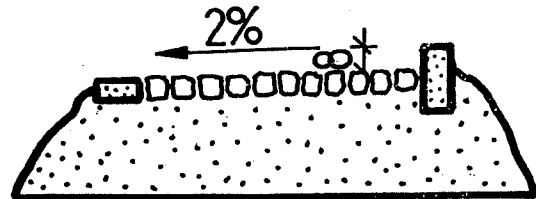

Schnitt B-B

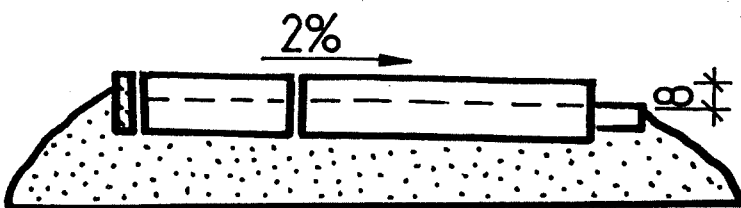

AZ Bau
Geradstetten

Gehweg mit
Eckausrundung

M 1: 25

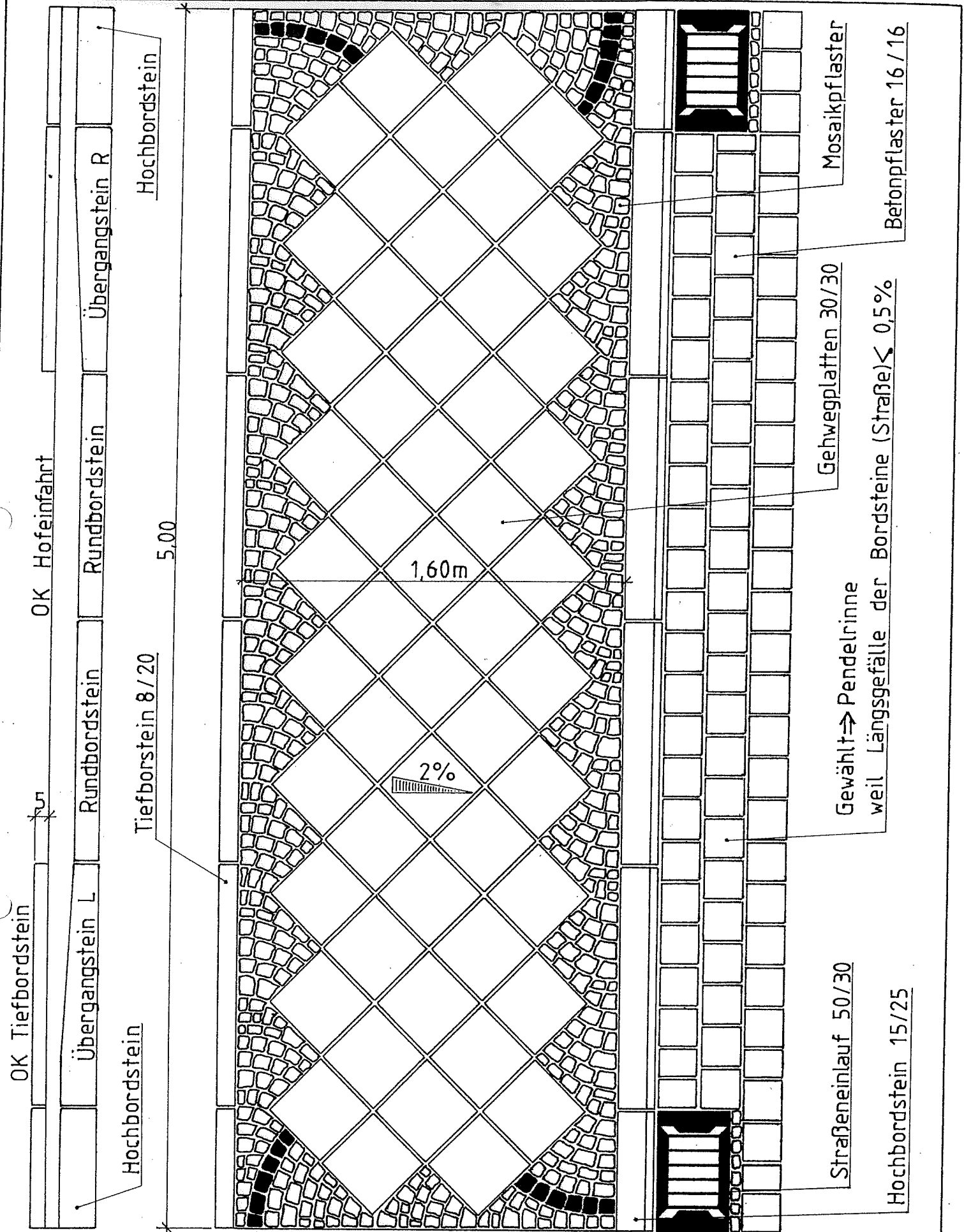

ABZ-BAU
II 8/19

Herstellen einer Einfahrt
mit Pendelrinne

Bl. Nr.: 88
Maßstab 1:20

II 8/19

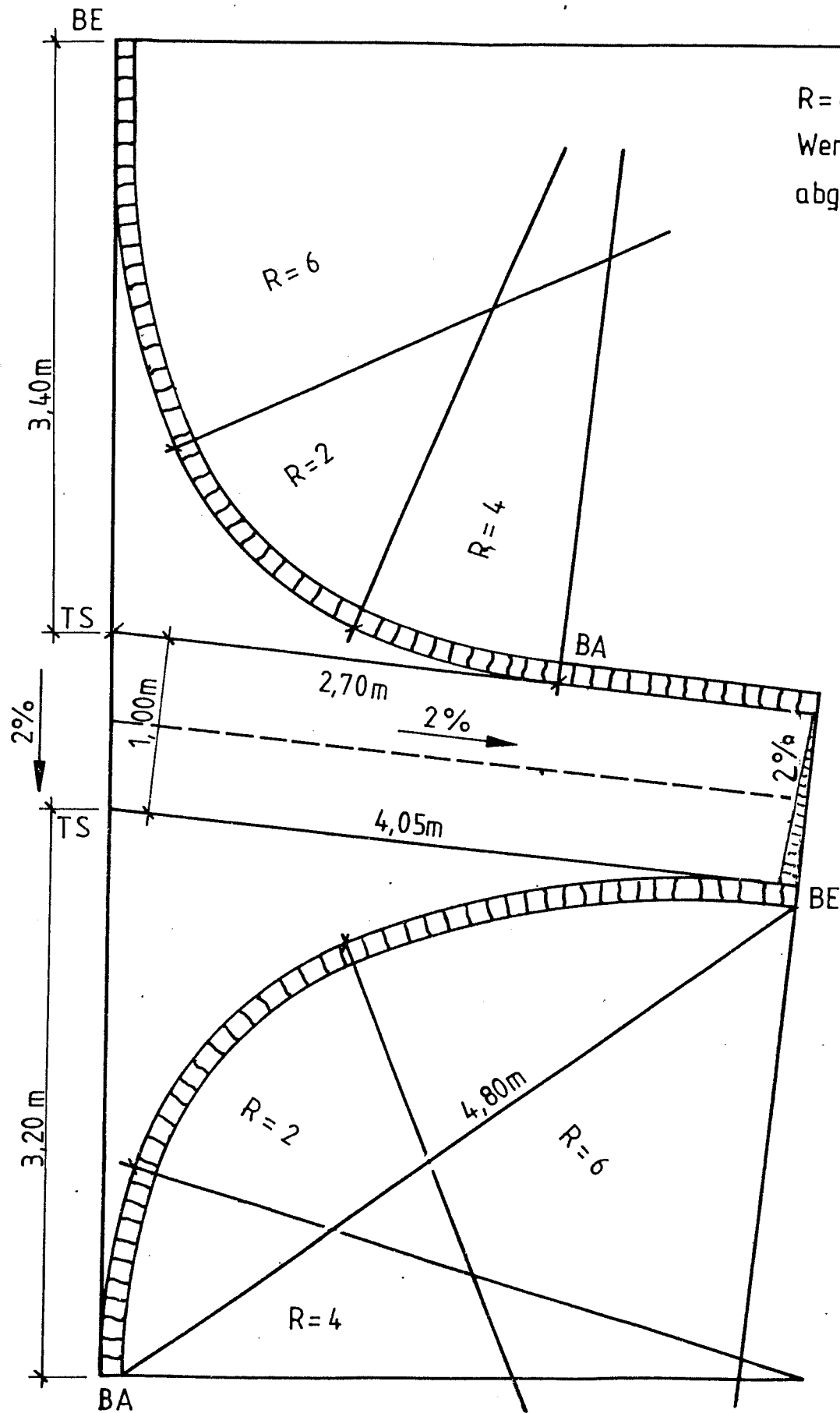

R=4 u. R6
Werden über X,Y
abgesteckt

X	Y
R=4	
1,20m	0,18m
R=6	
2,40m	0,48m

SCHNITT

A-A

5cm

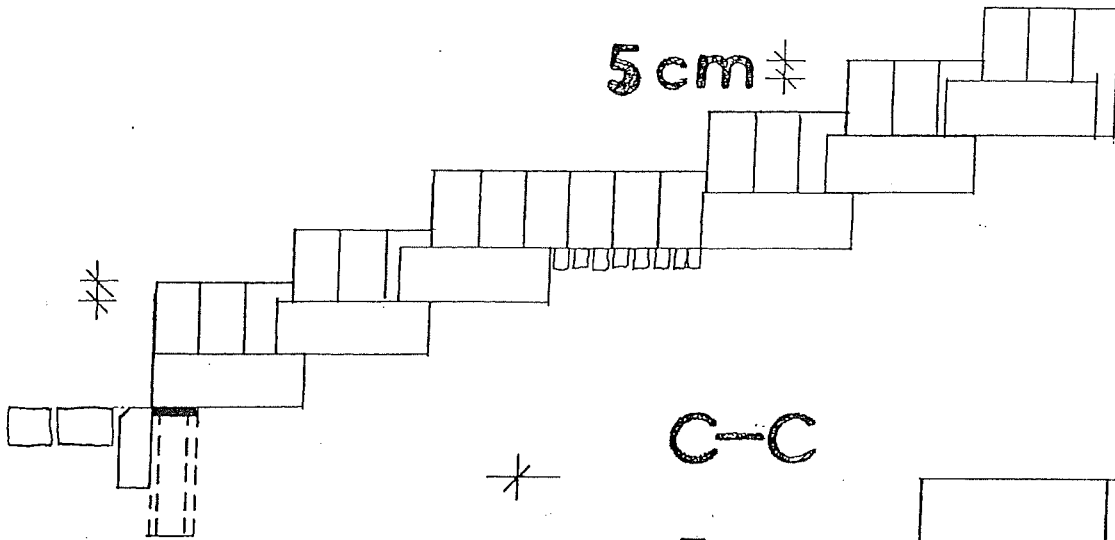

C-C

5cm

10m

2%

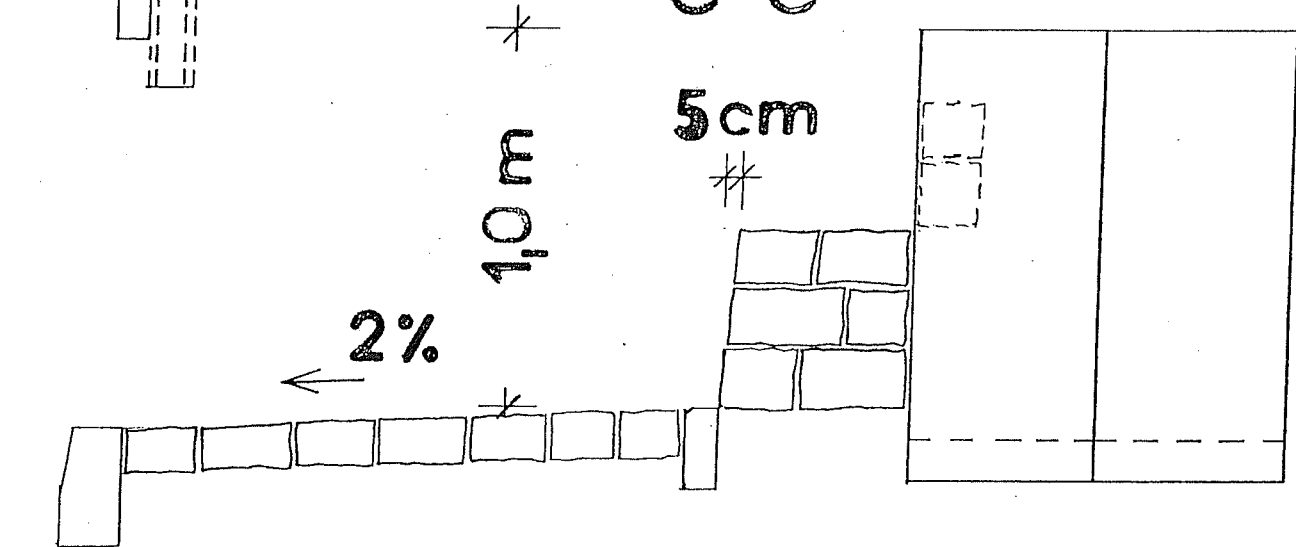

E-E

20cm

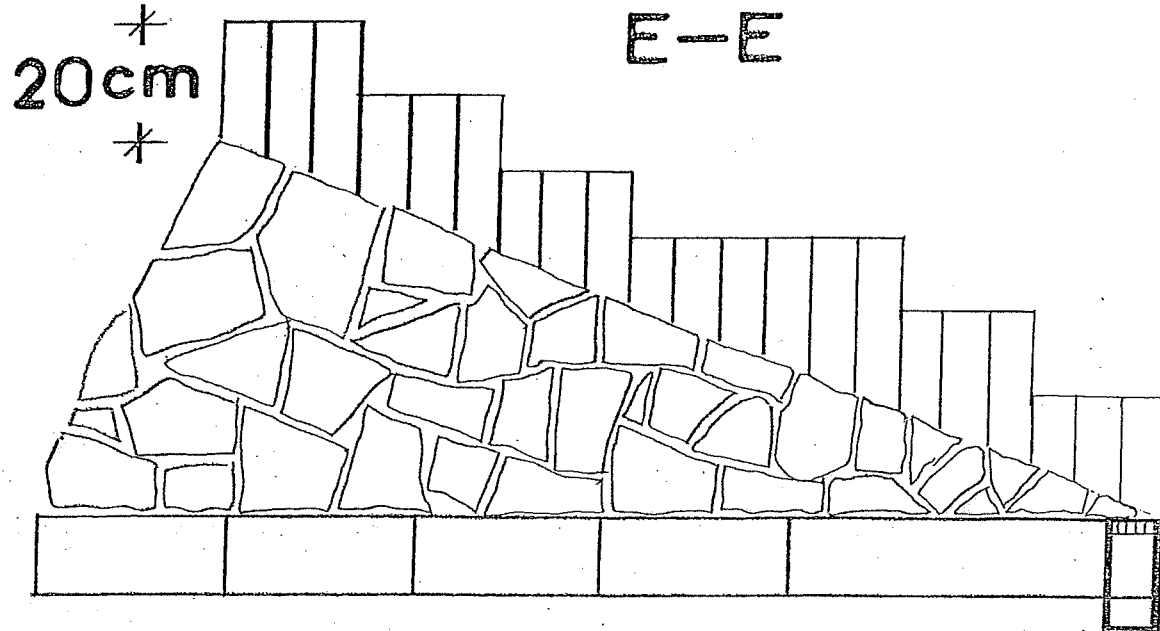

S
an
de
Be
un
Sic
I
zer
- i
- i
- i
- ir
- ir
- K
D
pen,

TE

B-B

RAUSTRICH

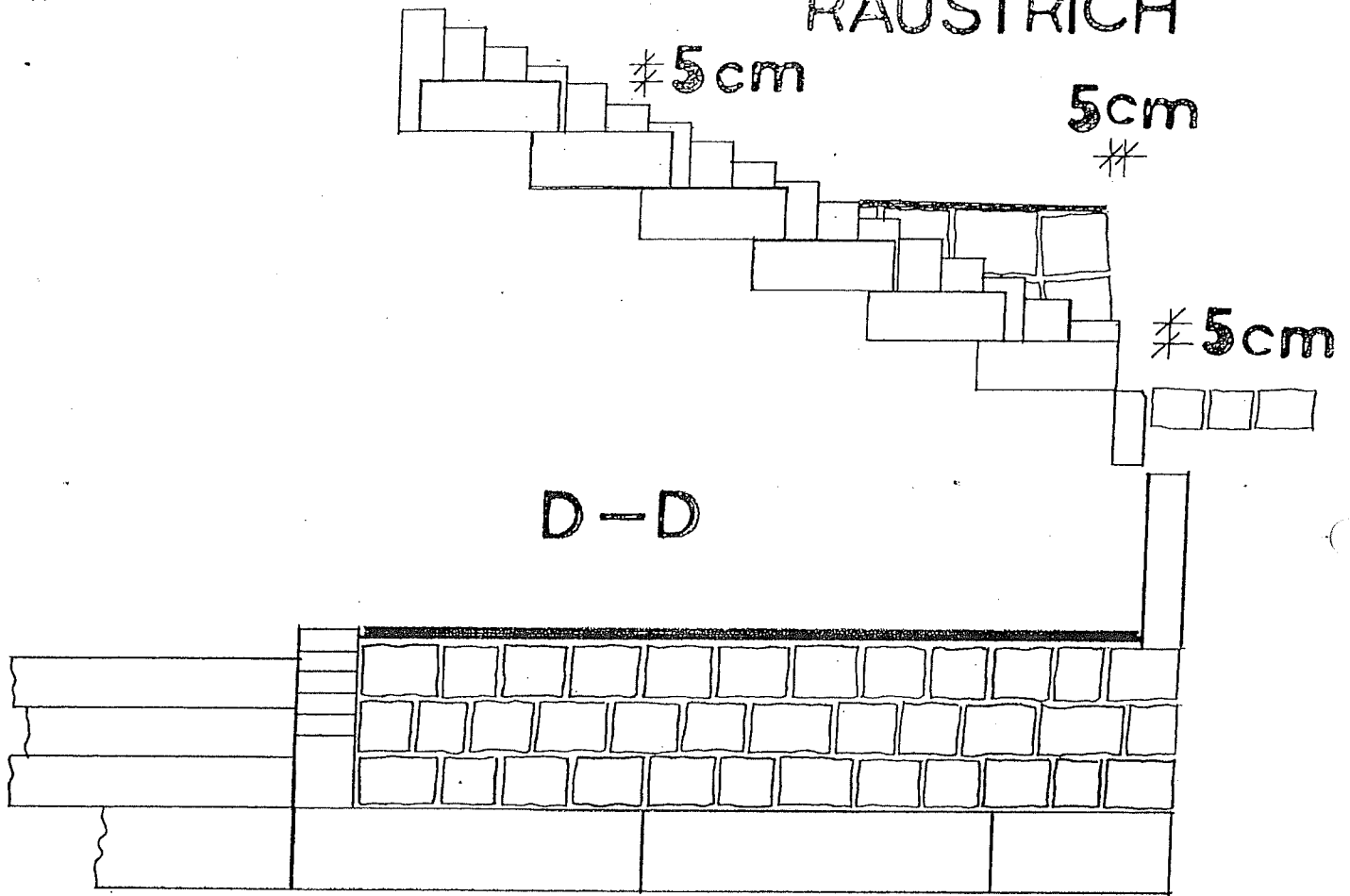

Schrittmaßregel

$$2 \cdot s + a = 59 - 65 \text{ cm}$$

Darin bedeuten
und

s die Steigung in cm
a die Auftrittsweite in cm.

Daneben kontrolliert man das Steigungsverhältnis mit

Quemlichkeitsformel

$$a - s = 12 \text{ cm}$$

der

Sicherheitsformel

$$a + s = 46 \text{ cm} \pm 1 \text{ cm}$$

Das Maß für die Steigung s richtet sich nach der Benutzungsgruppe und beträgt nach Erfahrung bei Treppen

Freien	14 - 16 cm
Schulen	15 - 16,5 cm
Kinos, Theatern	15 - 17 cm
Verwaltungsgebäuden	16 - 17 cm
Wohnhäusern	16 - 19 cm
Rollertreppen	18 - 21 cm

In den meisten Landesbauordnungen schreiben für Treppen, die zu Aufenthaltsräumen führen, vor:

Steigung s höchstens 19 cm
Auftritt a mindestens 26 cm
In jedem Treppenlauf müssen Steigung und Auftritt für jede Stufe gleich groß sein!

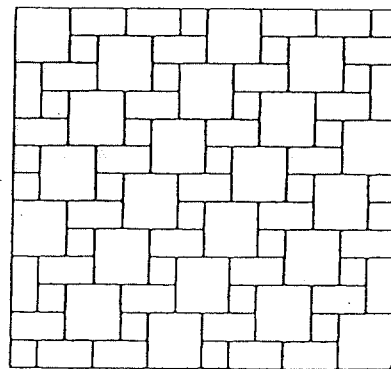

Iffezheimer Verband

Stein 1: 20,1 x 20,1 cm

Materialbedarf: 14,28 Stück/m²

Stein: 10 x 20 cm

Materialbedarf: 14,28 Stück/m²

Anfängerstein: 10 x 20 cm

Materialbedarf: 1,5 Stück/lfm

Zierstein: 10 x 10 cm

Materialbedarf: 14,28 Stück/m²

TR

TIEFBORD

BETONVERBUNDSTEINE

2%
↓

HOFEINFAHRT

BIRCO RINNE

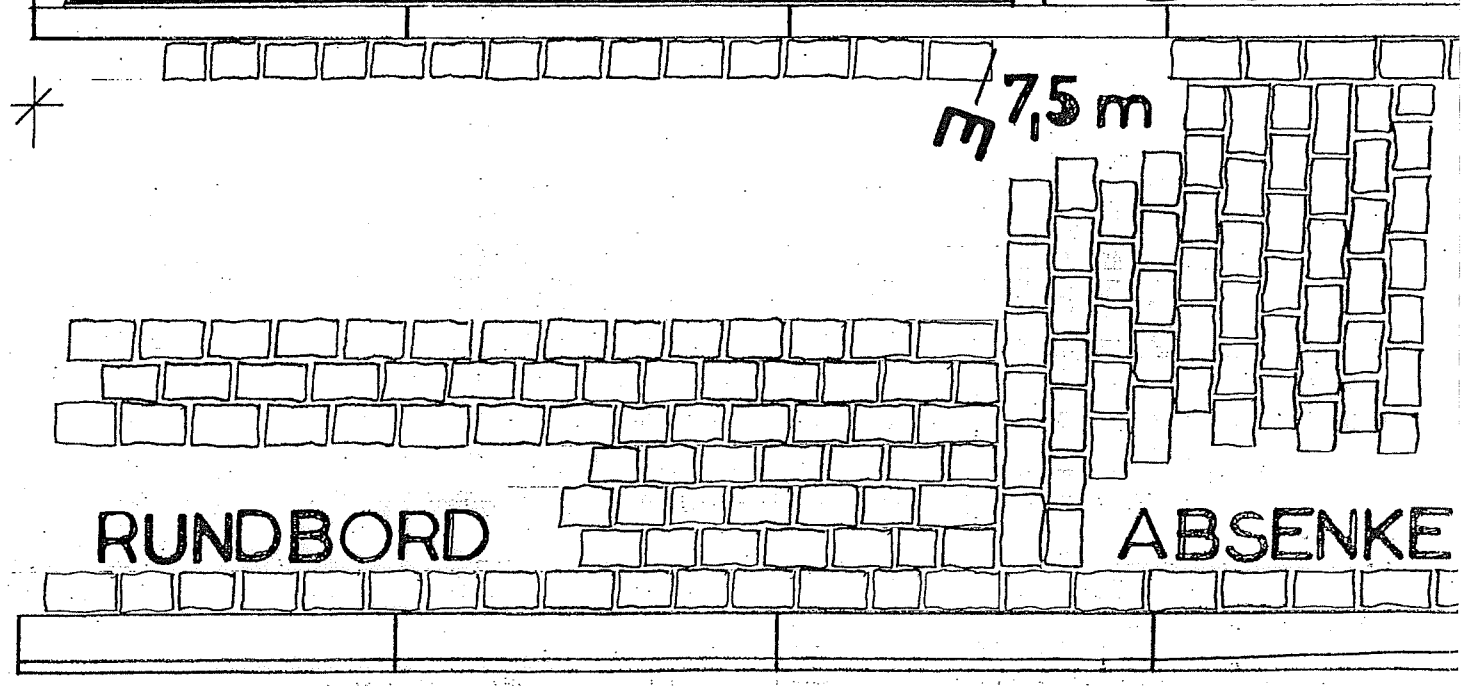
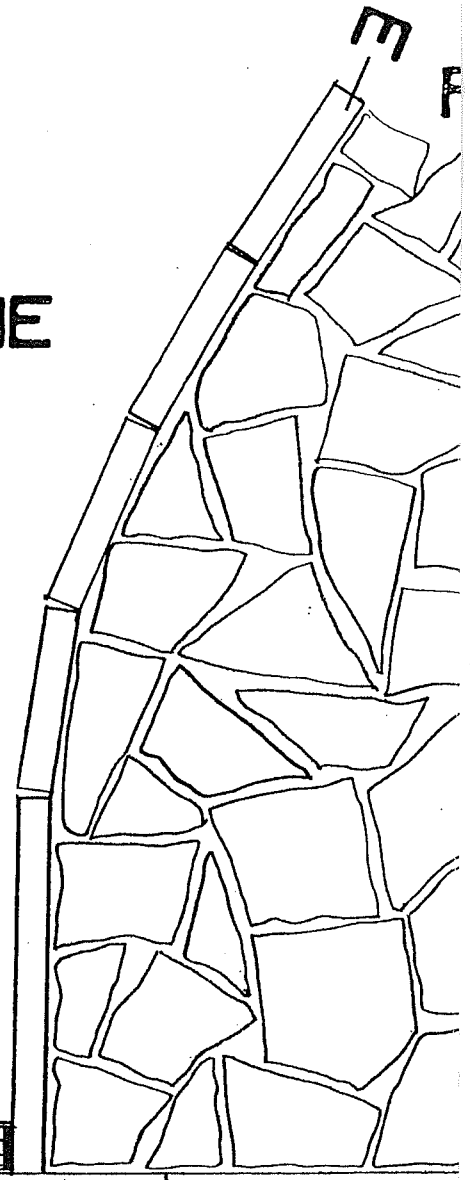

RUNDBORD

ABSENKE

STREPPEN HAUSEINGANG

LUSSBAUSTEINE



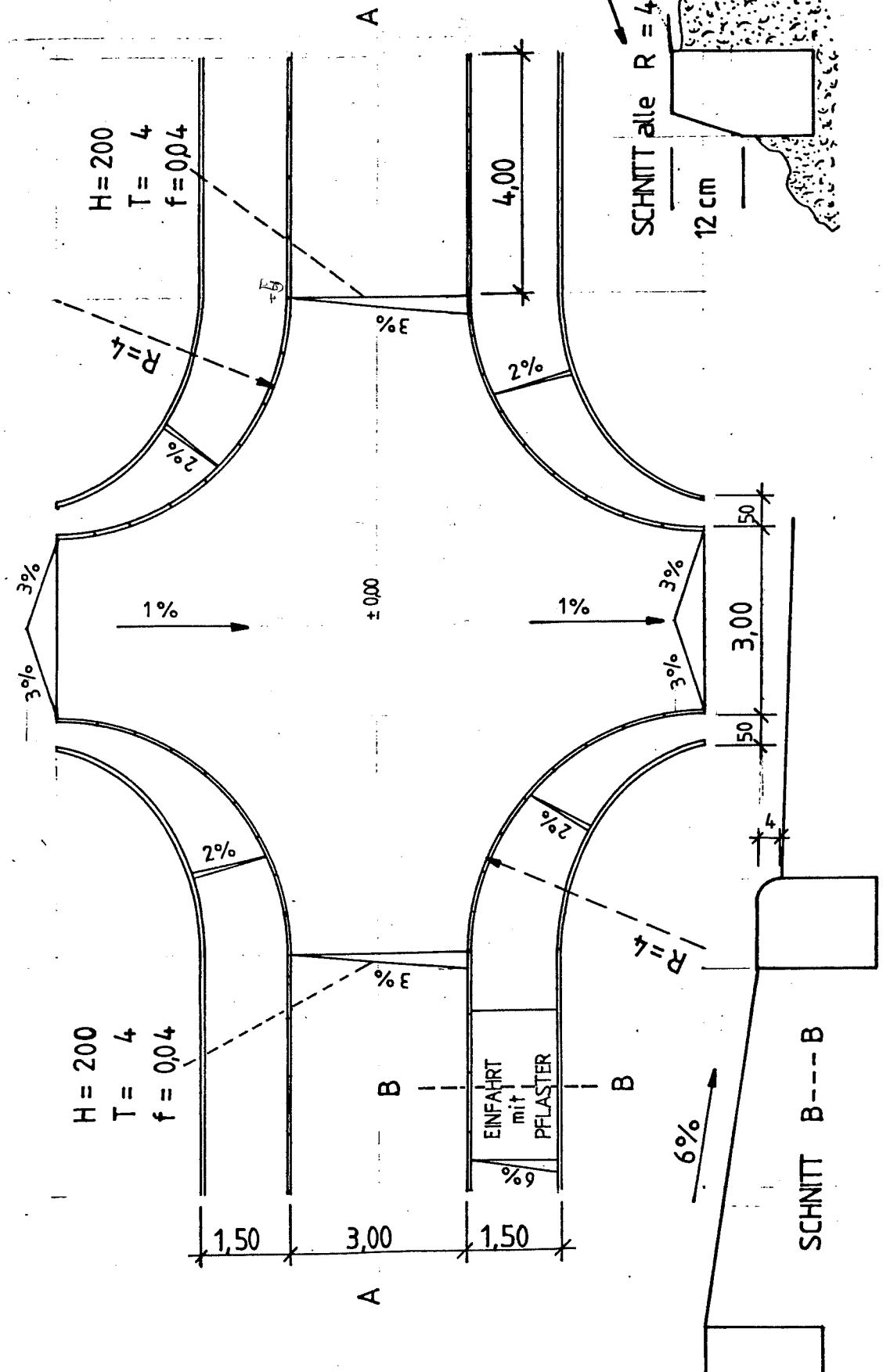

KREUZUNG

M =
1:100

SCHNITT A---A

$H=200$
 $T=4$
 $f=0,04$

$H=200$
 $T=4$
 $f=0,04$

$H=200$
 $T=4$
 $f=0,04$

$H=200$
 $T=4$
 $f=0,04$

1%

3%

1%

6%

3%

2%

2%

2%

2%

$R=4$

$R=4$

SCHNITT alle $R=4$

12 cm

2%
4 Ansch

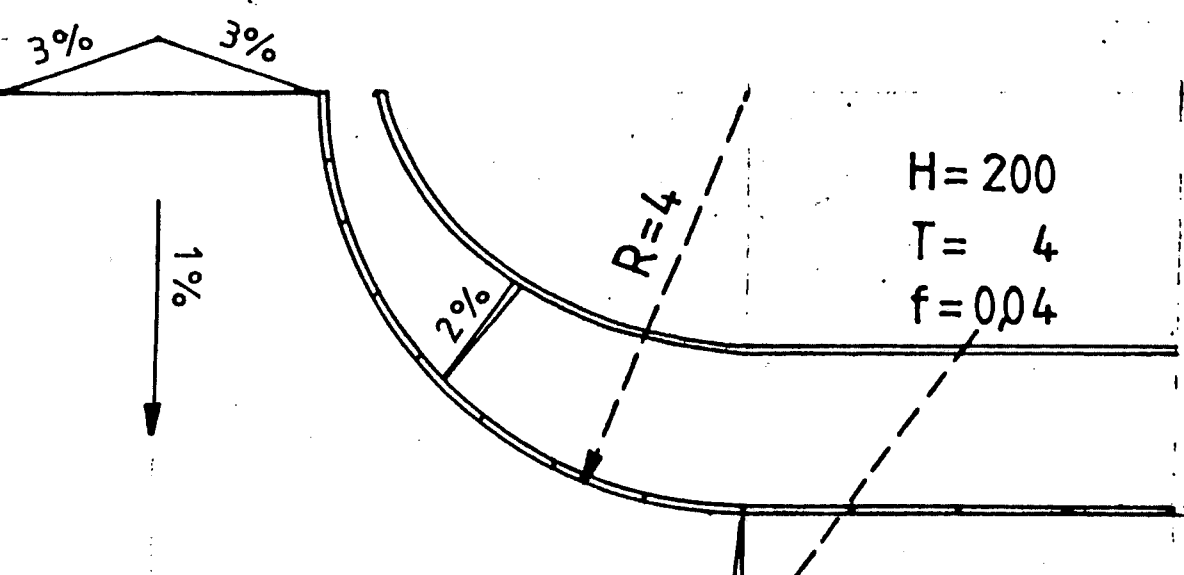

$H=200$
 $T=4$
 $f=0,04$

$\pm 0,00$

A

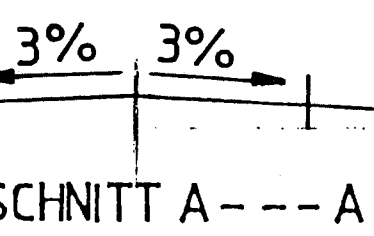
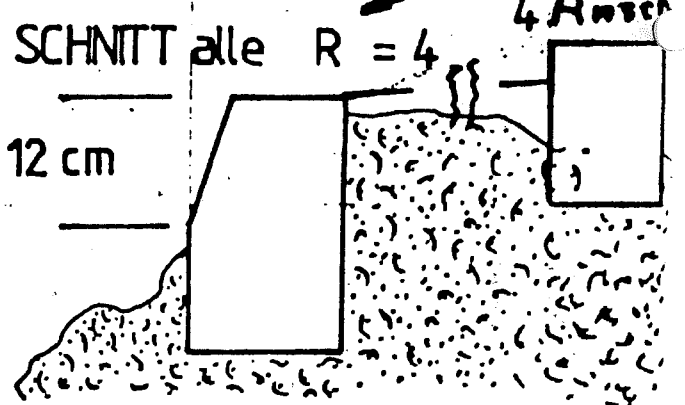
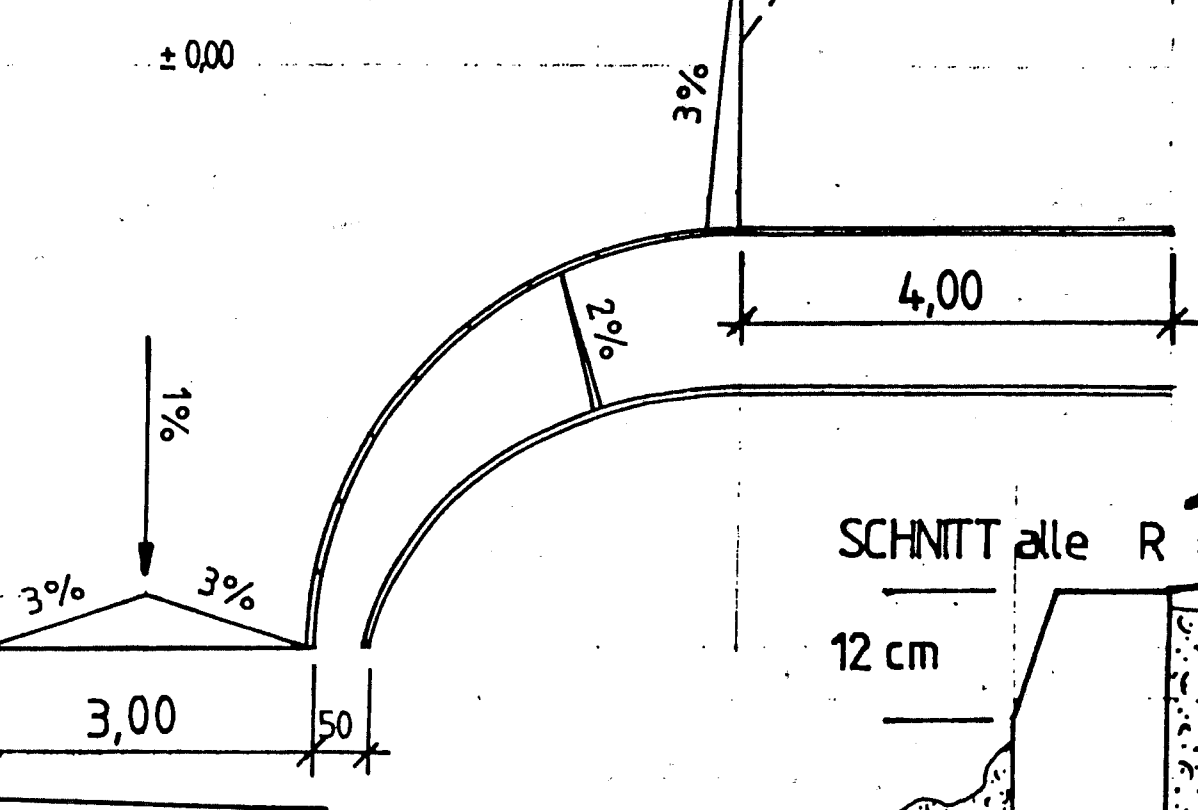

$H=200$
 $T=4$
 $f=0,04$

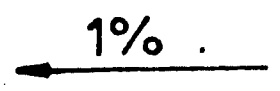

KREUZUNG

M = 1:100

H = 200
T = 4
f = 0,04

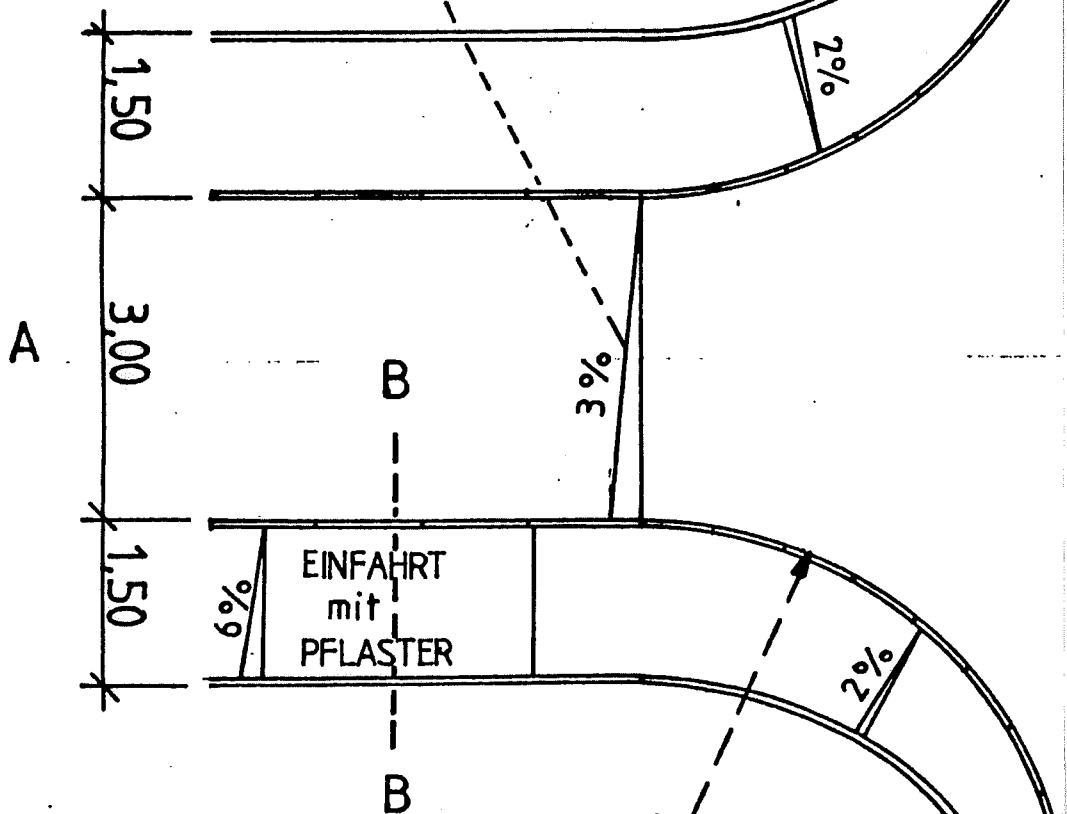

SCHNITT B---B

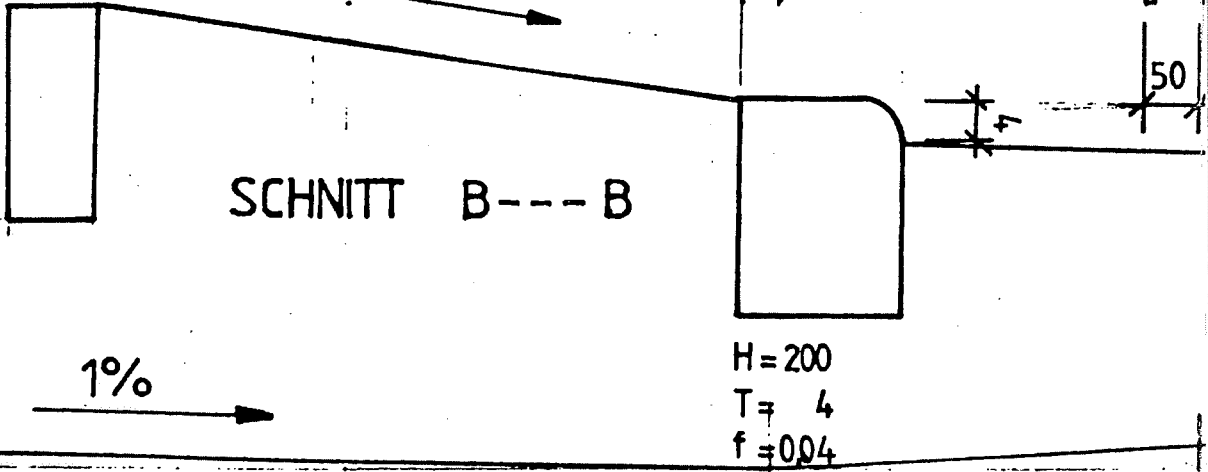

H = 200
T = 4
f = 0,04

II 12/11

KREUZUNG

M = 1.100

$H = 200$
 $T = 4$
 $f = 0,04$

A

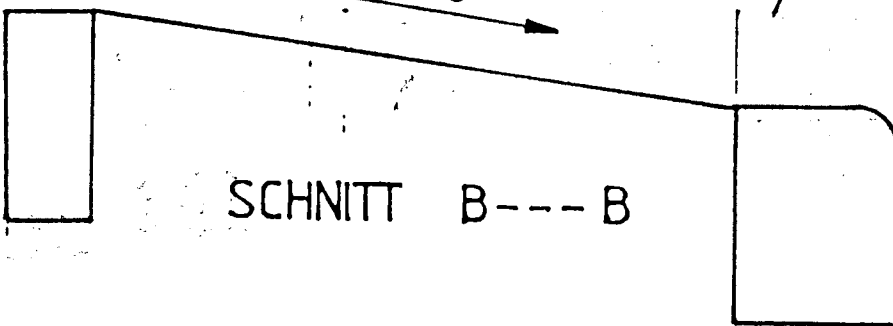
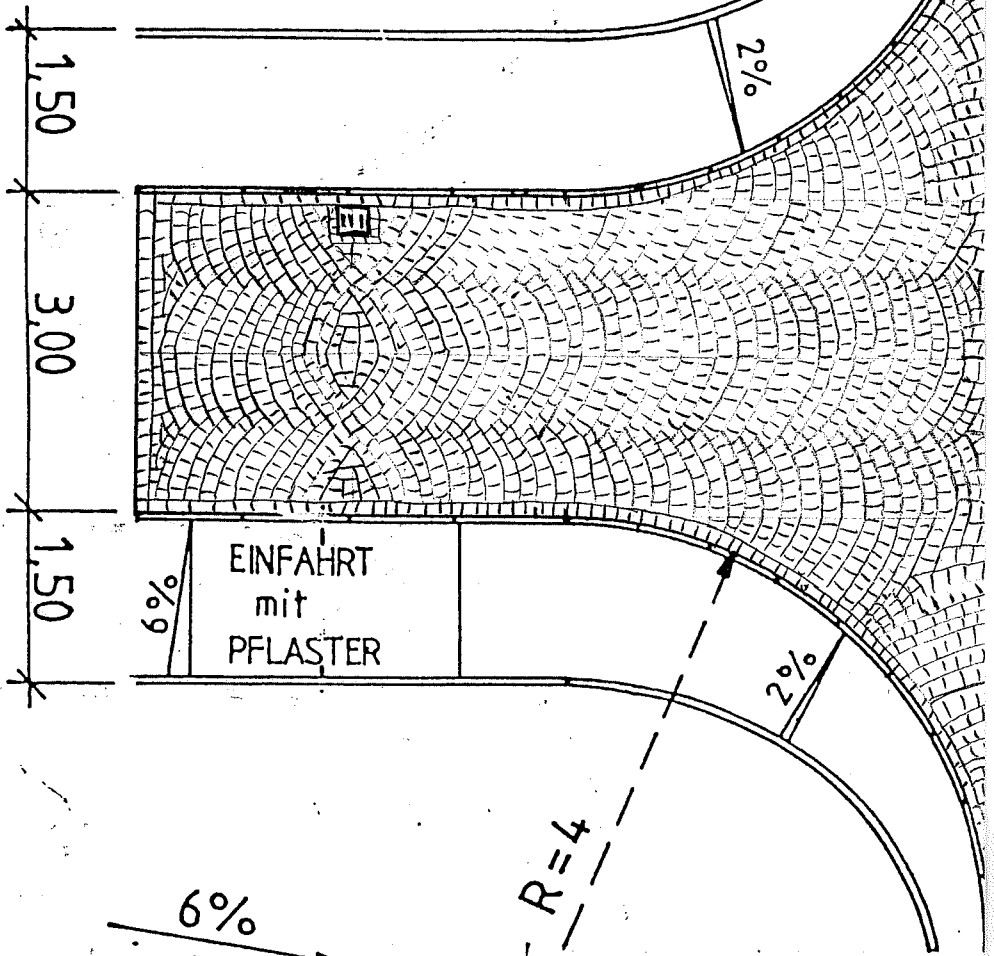

SCHNITT B---B

$H = 200$
 $T = 4$
 $f = 0,04$

1%

6%

$R = 4$

2%

2%

50

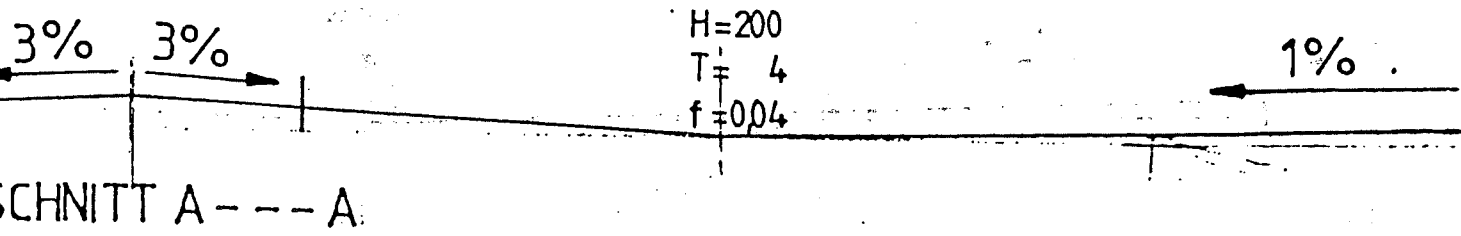
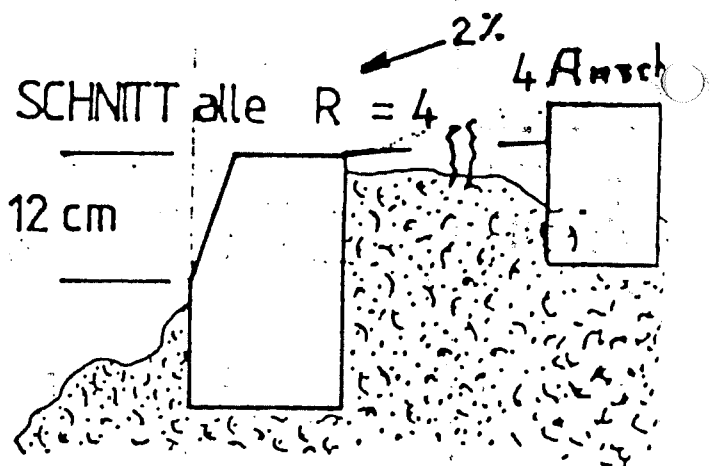
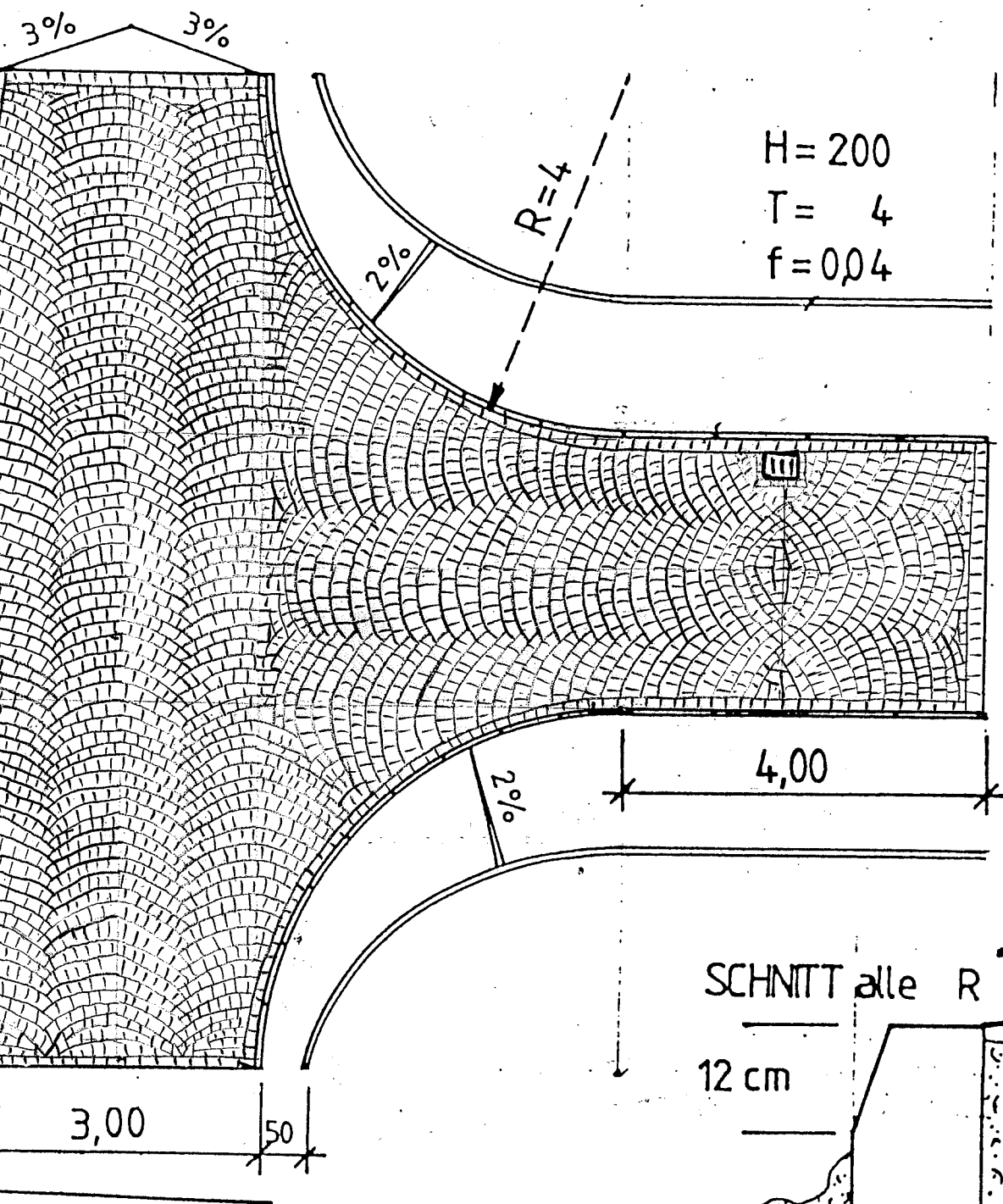

Draufsicht

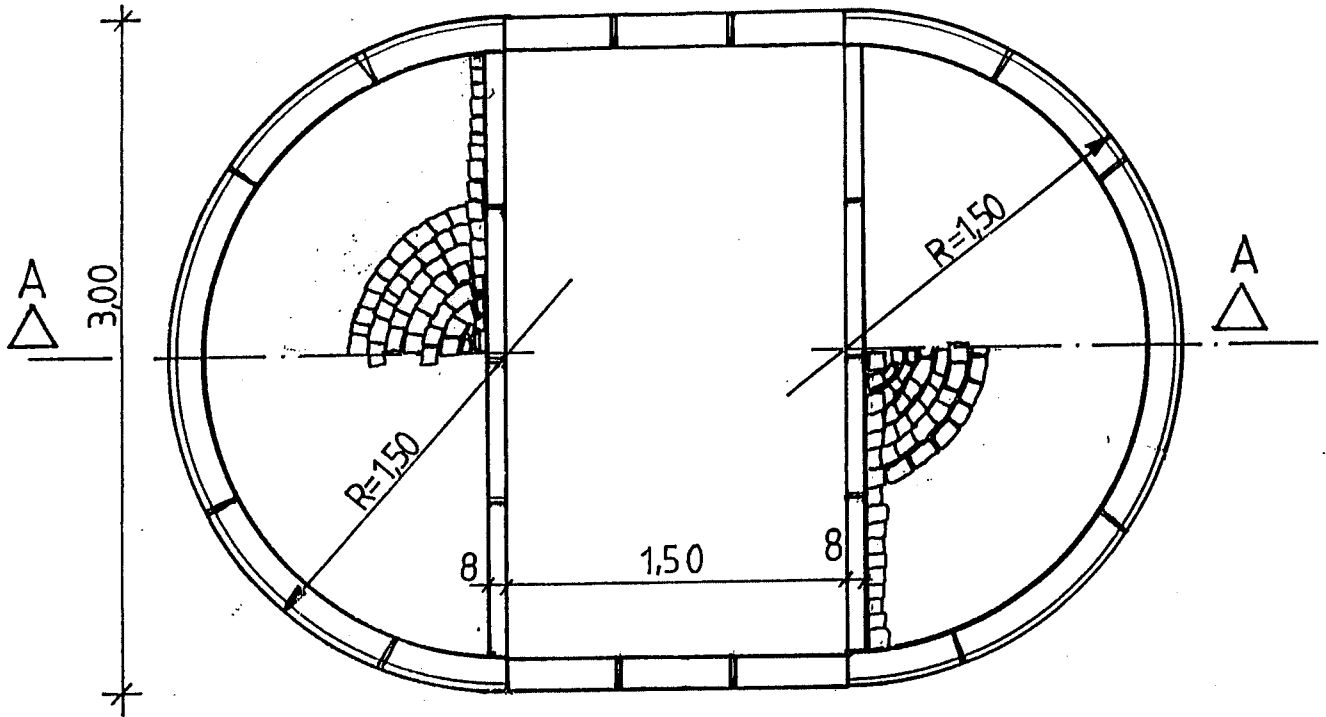

Schnitt A--A

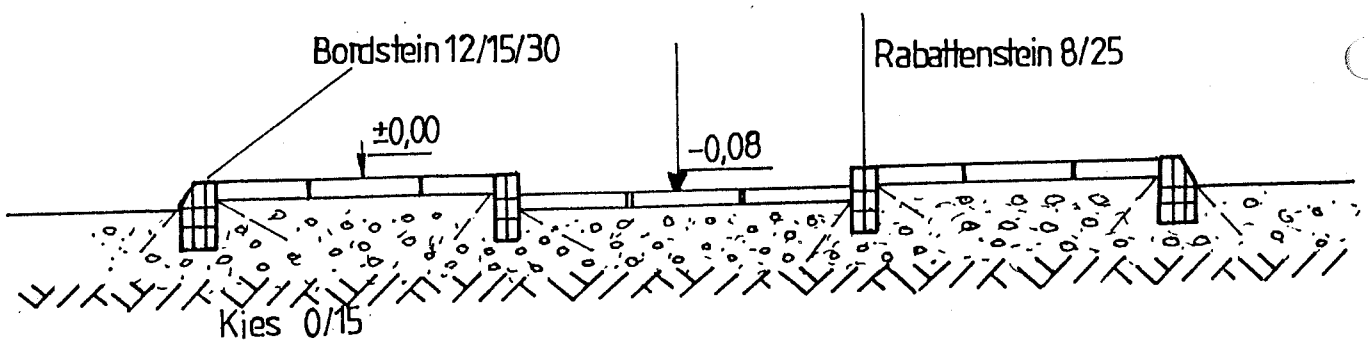

Verkehrinsel R=1,5

M:1=33,33

Draufsicht

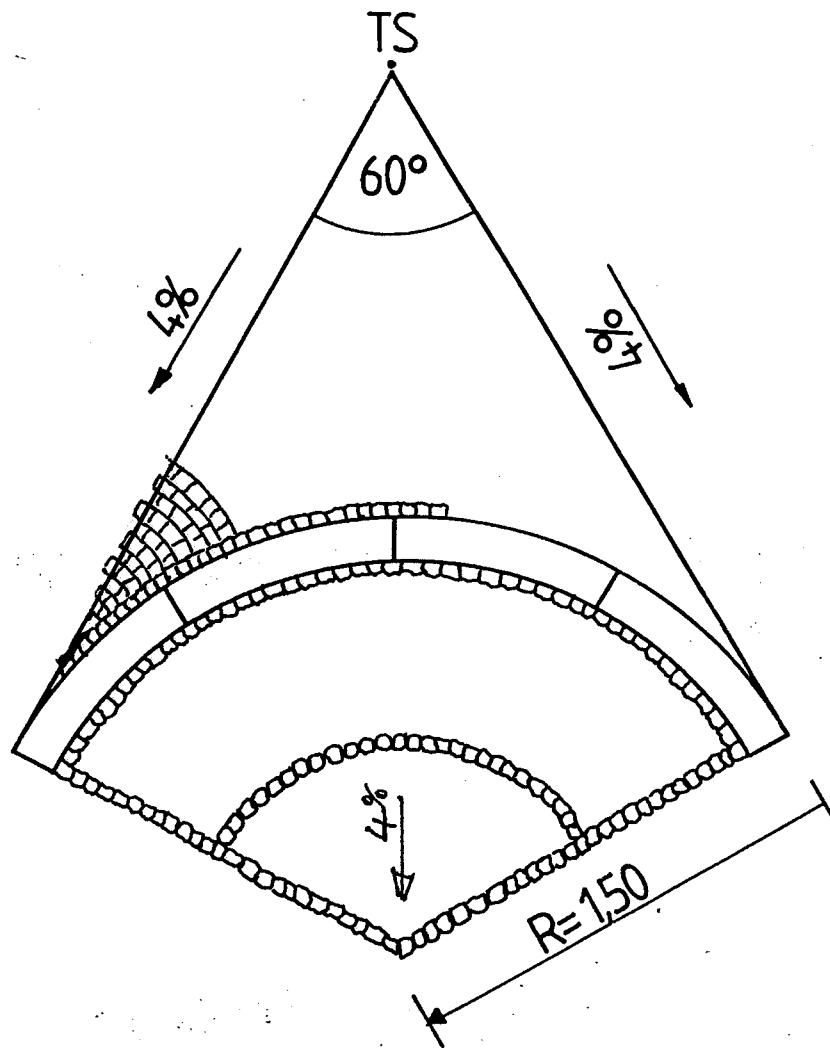

Schnitt

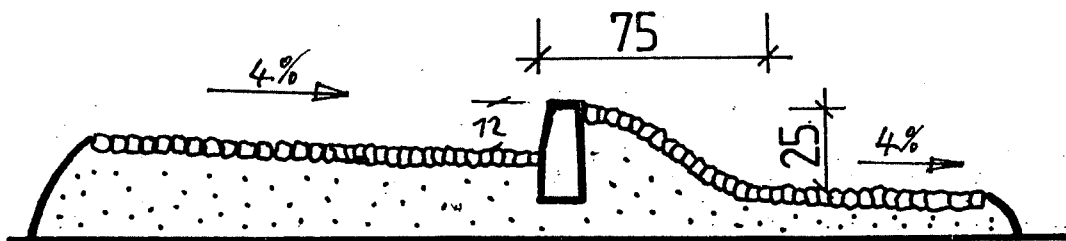

AZ Bau
Geradstetten

Radius 150 im
Spitzen Winkel

M 1:25

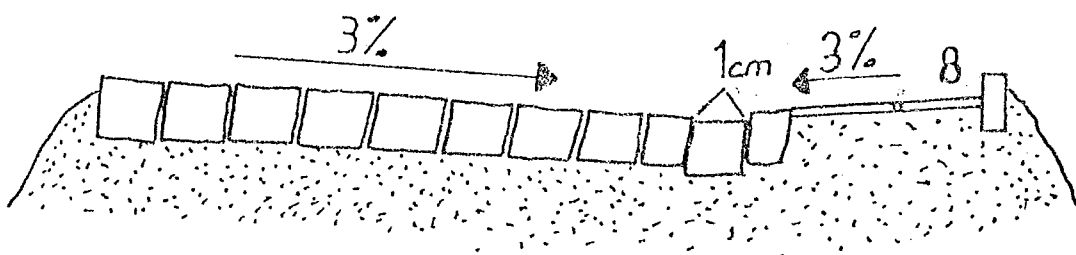
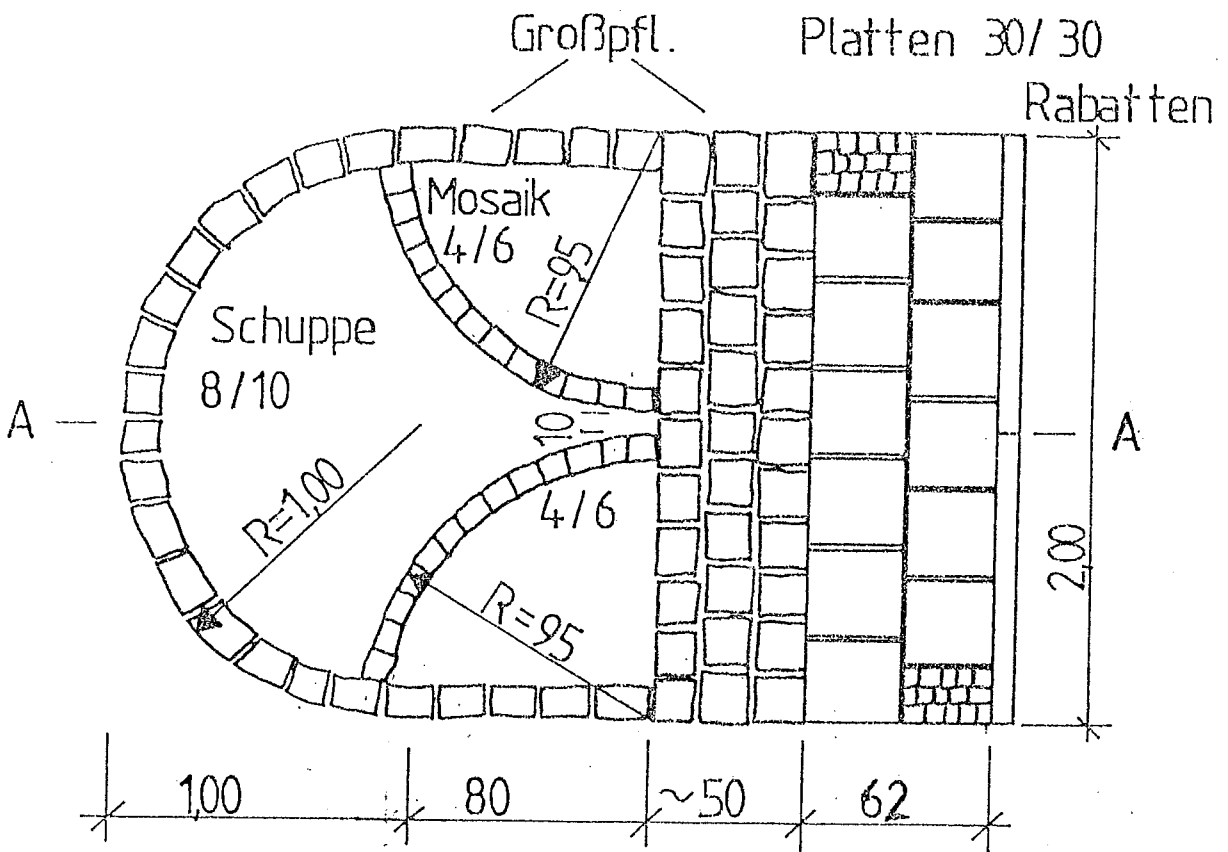

Schnitt A-A

<p>AZ Bau Geradstetten</p>	<p>Schuppe-Kandel-Gehweg</p>	<p>M 1:20</p>
--------------------------------	------------------------------	---------------